

MOTOR GRADER

GD511A-1

FLYWHEEL HORSEPOWER: **135 HP** 101 kW @2900 RPM
OPERATING WEIGHT: **10800 kg** 23,810 lb

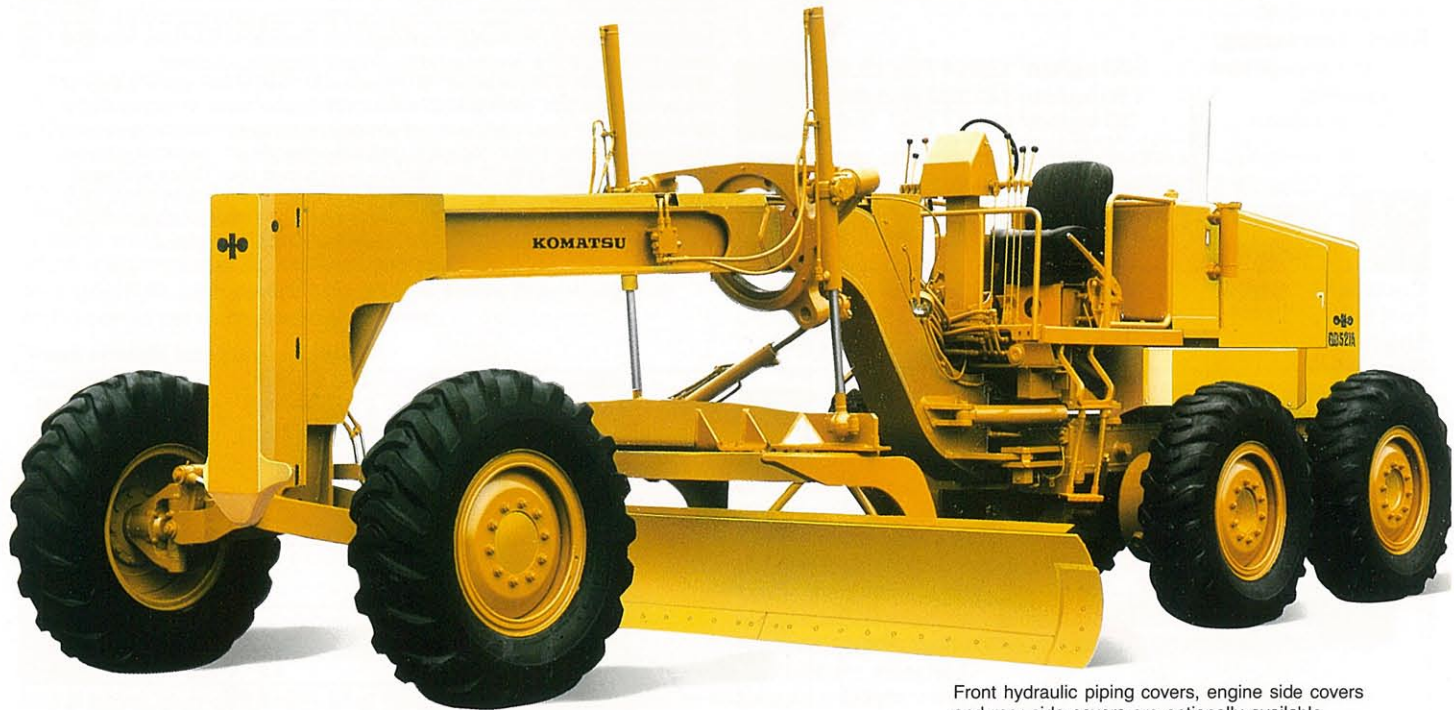

Front hydraulic piping covers, engine side covers and rear side covers are optionally available. Model shown may include other optional equipment.

- Sturdily-built main frame and tough power train make it easy to complete heavy-duty jobs.
- The performance-proven Komatsu S6D95L diesel engine delivers a healthy 135 HP (101 kW), more than enough for the most difficult of tasks.
- A non-spin differential with automatic locking and unlocking can be installed as an option on the single reduction final drives, assuring the optimum in smooth steering.
- Tough efficient hydraulic system makes best use of every part of the machine.
- Wide blade range and frame articulation make this machine ready for a real variety of diverse operations.
- Ideal weight distribution makes it possible to dig harder ground with excellent machine stability.
- Because of its combination of blade sideshifting and frame articulation, the GD511A can assume a wide variety of operating positions.
- Operator's compartment is mounted on rear frame, giving the driver excellent visibility and ease of operation.

KOMATSU

High reliability

Sturdily-built main frame and tough power train make it easy to complete heavy-duty jobs.

The main frame is of box-section construction with flanges, and reinforced with additional side plates around the blade cylinder brackets where sudden, heavy-duty shocks occur. This results in substantially increased main frame durability. This tough construction also resists torsional changes when an eccentric load is applied to either of the two blade lift cylinders.

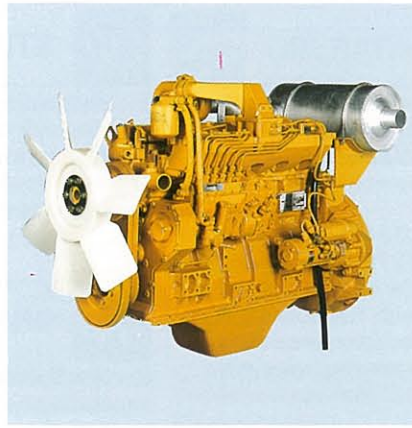

The performance-proven Komatsu S6D95L diesel engine delivers a healthy 135 HP (101 kW), more than enough for the most difficult of tasks. The HYDROSHIFT transmission is controlled by a single lever for ease of use, and is designed to minimize engine power loss.



Hydraulic blade tip control is optionally available.

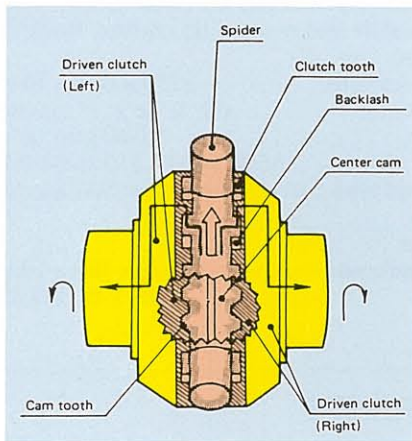

A non-spin differential with automatic locking and unlocking can be installed as an option on the single reduction final drives, assuring the optimum in smooth steering.

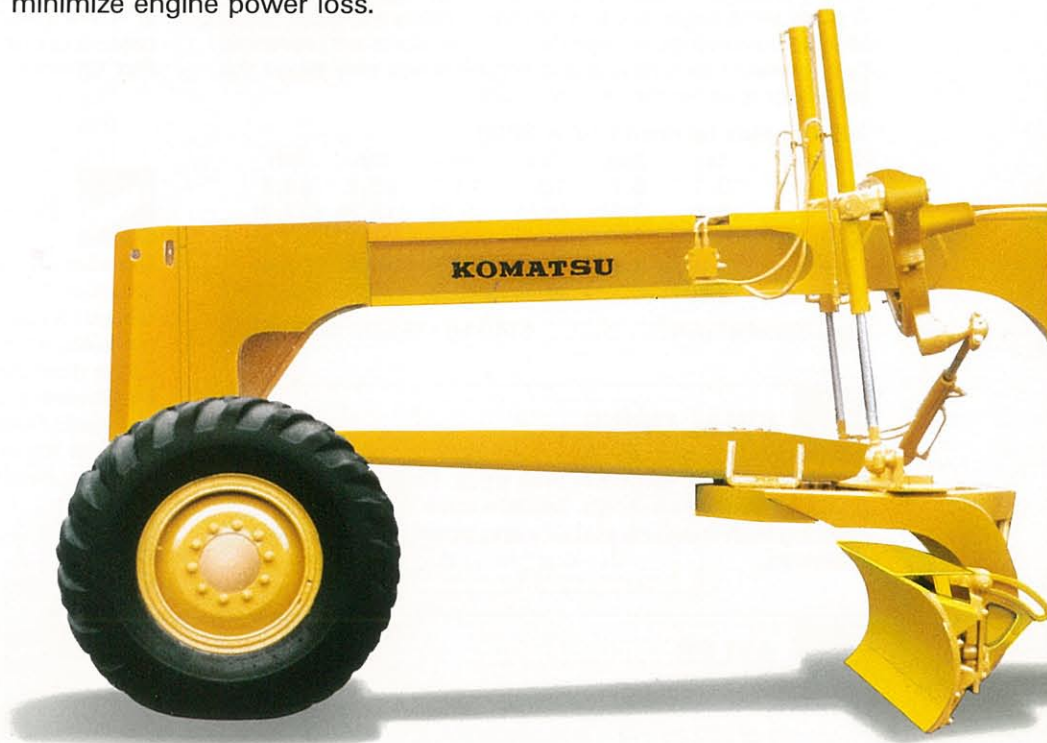

Tough, efficient hydraulic system makes best use of every part of the machine. The control system consists of a gear pump and the flow divider. The number of mechanically-operated parts has been greatly reduced, increasing hydraulic system reliability. Furthermore, pilot check valves are built into the blade lift, front

axle lean and frame articulation. This prevents drifting of these cylinders, and results in high finishing accuracy. These valves also help maintain the original equipment position and to prevent drift if the control lever is operated with the engine stopped.

High productivity

Wide blade range and frame articulation make this machine ready for a real variety of diverse operations. With its excellent shoulder reach and blade lift and drop, the GD511A-1 can perform a versatile range of blade operations with ease. High-bank cutting of the blade can be performed up to angles of 90° on both left and right end. Bank pin setting is easily performed from the operator compartment.

Ideal weight distribution makes it possible to dig harder ground with excellent machine stability. Since the front wheels are loaded with the optimum weight distribution to prevent side slip, outstanding operational stability is assured especially during operations that impose heavy side thrust on the machine.

Because of its combination of blade sideshifting and frame articulation, the GD511A-1 can assume a wide variety of operating positions, virtually guaranteeing the optimum in operating efficiency and productivity.

1. **Offset leveling:** Place front wheels on the levelled ground and rear wheels on the ground to be levelled. This operating position minimizes machine's oscillation caused by unevenness of the ground, assuring precise leveling.

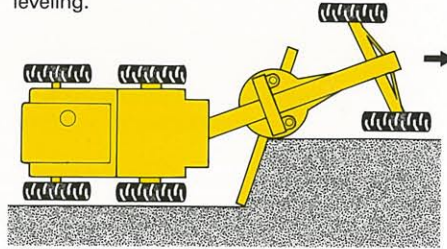

2. **Leveling on inclines:** With the use of frame articulation, center of gravity can be shifted to the upward side of the slope, resulting in increased machine stability.

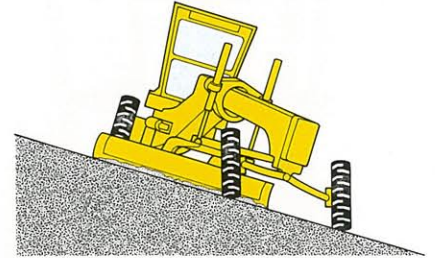

3. **Low bank cutting with front wheels in offset status:** Settle front wheels on the incline and rear wheels on flat ground. This enables precise bank cutting.

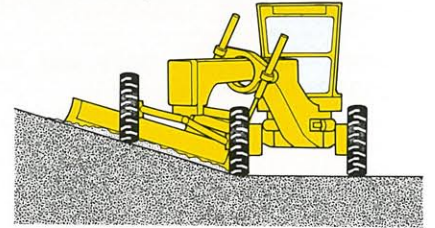

4. **Digging up extra-hard ground:** Place either end of the blade at the longitudinal center of the machine. This method facilitates the digging out of deeply rooted rocks and stones.

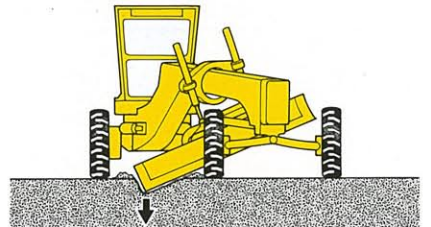

5. **Refilling:** By placing front wheels in the ditch, side-to-side sliding of wheels is prevented. Precise leveling can also be performed in this position, since side slip of the rear wheels is reduced and the rear wheels travel over already refilled ground.

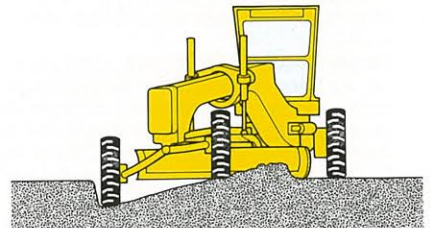

Improved operating comfort



Operator's compartment is mounted on rear frame, giving the driver excellent visibility and ease of operation.

Since the operator's compartment is mounted on the rear frame and not affected by movement of the main frame, the operator can observe the machine at all times—even if the main frame is in the articulated

or offset position—without the need for looking behind or twisting the body around. Articulated turns are performed with the same ease as steering an ordinary passenger car, too; backing up is also easy.

For safer operation, the compact engine compartment ensures plenty of view to the rear.

SPECIFICATIONS



ENGINE

Komatsu S6D95L, 4-cycle, water-cooled, overhead-valve, turbocharged diesel engine of 6 cylinders with 95 mm (3.74") bore × 115 mm (4.53") stroke and 4.89 ltr. (298 cu.in) piston displacement.

Flywheel horsepower:

135 HP (101 kW) at 2900 RPM (SAE J1349)

137 PS (101 kW) at 2900 RPM (DIN 6270 NET)

Direct-injection for fuel economy. Mechanical all-speed governor. Gear pump-driven force lubrication with full-flow filter. Dry-type air cleaner with automatic dust evacuator, precleaner and dust indicator for extended element service intervals. 24 V/5.5 kW electrical starting motor. 24 V/25 A alternator. 2 × 12 V/100 Ah batteries.



HYDROSHIFT TRANSMISSION

The Komatsu HYDROSHIFT transmission consists of planetary gears and hydraulically actuated and force-lubricated multiple-disc clutches, assuring light-touch, effort-minimizing shifting. Both speed shifting and direction changes are completed by a single lever. With the inching pedal, precise finishing operation and smooth machine starts are ensured. A super wide range of 6 forward and 6 reverse speeds match all job requirements. Accidental machine starts are prevented by a gearshift lock device and engine starts only when the shift lever is set in the neutral position.

Travel speeds (at rated engine RPM)

	1st	2nd	3rd	4th	5th	6th
Forward						
km/h	3.4	6.1	10.7	14.1	25.5	44.5
(MPH)	(2.1)	(3.8)	(6.6)	(8.8)	(15.8)	(27.7)
Reverse						
km/h	4.2	7.5	13.1	17.3	31.1	54.4
(MPH)	(2.6)	(4.7)	(8.1)	(10.8)	(19.3)	(33.8)

Max. drawbar pull 6140 kg (13,535 lb/60.2 kN)



FINAL DRIVE

Spiral bevel gear reduction final drive. Roller-chain tandem drives for four rear wheels. Tandem case swings up to 13°, assuring high machine stability and positive traction during operation.



AXLES

Front axle: Reverse Elliot-type front axle with a center ground clearance of 610 mm (2') and oscillation angle of 32° (total) assures stable machine travel. Hydraulic front wheel leaning (20° to each side).

Rear axle: Full-floating rear axle is made of forged heat-treated steel.



WHEELS

Front and rear tires 13.00-24-8PR (G-2) traction-type tubed tires

Rims 8.00TG × 24 (SDC)

Inflation pressure 1.8 kg/cm² (25.6 PSI/177 kPa)



STEERING

Full-hydraulic orbitrol type steering control system with one steering cylinder is directly actuated on the knuckle arm. Maximum steering angle of front wheels is 49° left and right.

Frame articulation angle 27°, left and right

Min. turning radius (frame articulated) 6.6 m (21'8")



BRAKES

Service brakes: Foot-operated, hydraulically actuate internal expanding type on 4 rear wheels, hydraulic booster for sure braking.

Parking brake: Mechanical, internal expanding type actuated on transmission shaft.



FRAMES

Frames are articulated by two hydraulic cylinders. Box-sectioned front frame is steel-plate-welded constructed. One-piece-frame design for the front frame on which hydraulic pipings are installed offers excellent front visibility for more precise operations.

Front frames section (width × height) 280 × 294 mm (11.0" × 11.6")



BLADE EQUIPMENT

Drawbar: A-shaped, U-section press-formed and welded construction for maximum strength.

Circle: Hydraulically controlled, internal gear type circle with six guide shoes for smooth 360° rotation.

Circle diameter (outer) 1300 mm (4'3")

Moldboard: Box-section constructed with wear-resistant steel. Hydraulic blade sideshift and manual tip control. Reversible end bits are attached.

Length × height × thickness 3710 × 645 × 16 mm (12'2" × 2'1" × 0.63")

Blade base 2540 mm (8'4")

Blade load 5585 kg (12,310 lb/54.8 kN)

Cutting edges: Curved type cutting edges meet SAE standard J739b.

No. of cutting edges 2

Length × height × thickness 1829 × 152 × 16 mm (6' × 6" × 0.63")



BLADE RANGE

All blade movements and position can be hydraulically controlled from the operator's seat.

Max. lift above ground 450 mm (1'6")

Max. drop below ground 535 mm (1'9")

Max. shoulder reach:

Left 2030 mm (6'8")

Right 2030 mm (6'8")

Max. bank cutting angle 90°

Cutting angle 29° ~ 77°



HYDRAULIC CONTROL UNIT

Hydraulic pumps: Tandem gear pump for work equipment and steering control.

Capacity . . . 62 ltr (16.4 U.S. gal) + 39 ltr (10.3 U.S. gal)

One gear pump for HYDROSHIFT transmission

Capacity 88 ltr. (23.2 U.S. gal)

Hydraulic motor: Orbit-type hydraulic motor of 22 HP

(16 kW) output power is used for blade rotation.

Hydraulic cylinders: Double-acting piston type hydraulic cylinders: two for blade lifting, one for drawbar sideshifting, one for blade sideshifting, one for front wheel leaning, one for front wheel steering and two for frame articulation. Pilot check valves assure positive cylinder action (excluding a blade sideshift cylinder).

Control valves: 3-spool and 4-spool type control valves for work equipment controls. Relief valve built into control valves for sure control.

Relief valve setting:

Work equipment . . . 200 kg/cm² (2844 PSI/19.6 MPa)

Steering 150 kg/cm² (2133 PSI/14.7 MPa)

Transmission 30 kg/cm² (427 PSI/ 2.9 MPa)



COOLANT & LUBRICANT CAPACITY (refilling)

Coolant 34 ltr. (9.0 U.S. gal)

Fuel tank 227 ltr. (60.0 U.S. gal)

Engine 9 ltr. (2.4 U.S. gal)

Transmission 34 ltr. (9.0 U.S. gal)

Tandem case (total) 78 ltr. (20.6 U.S. gal)

Final drive case 12 ltr. (3.2 U.S. gal)

Hydraulic oil 30 ltr. (7.9 U.S. gal)



OPERATING WEIGHT (approximate)

Operating weight, including rated capacity of lubricant, coolant, full fuel tank, hydraulic equipment, operator, 3710 mm (12' 2") blade and 13.00-24-8PR (G-2) traction-type tires, and the standard equipment.

On front wheels 3130 kg (6,900 lb)

On rear wheels 7670 kg (16,910 lb)

Total weight 10800 kg (23,810 lb)

STANDARD EQUIPMENT

ENGINE AND TRANSMISSION: 135 HP (101 kW) diesel engine. 24 V/5.5 kW starting motor. 24 V/25 A alternator. 2 x 12 V/100 Ah batteries. Corrosion resistor. Dry-type air cleaner with built-in centrifugal precleaner and automatic dust evacuator. Pusher type fan. Muffler. Hand throttle. Accelerator and inching pedals. HYDROSHIFT transmission.

METER AND GAUGES: Service meter. Water temperature gauge. Dust indicator. Battery discharge warning lamp. Engine oil pressure warning lamp. Parking brake warning lamp. Engine-preheat indicator.

MOLDBOARD: 3710 mm (12' 2") blade with two 6 feet cutting edges, reversible end bits. Hydraulic blade sideshift and manual tip control.

BRAKES: Foot-operated, internal expanding type service brakes with hydraulic booster. Hand operated, internal-expanding type parking brake.

TIRES: 13.00-24-8PR (G-2) traction-type tubed tires (front and rear)

OTHERS: Adjustable console. Adjustable seat. Horn. Panel lamp. Pilot check valves for blade lift, front wheel leaning, drawbar sideshift and frame articulation cylinders. Rear tow hitch. Operator guard.



DIMENSIONS

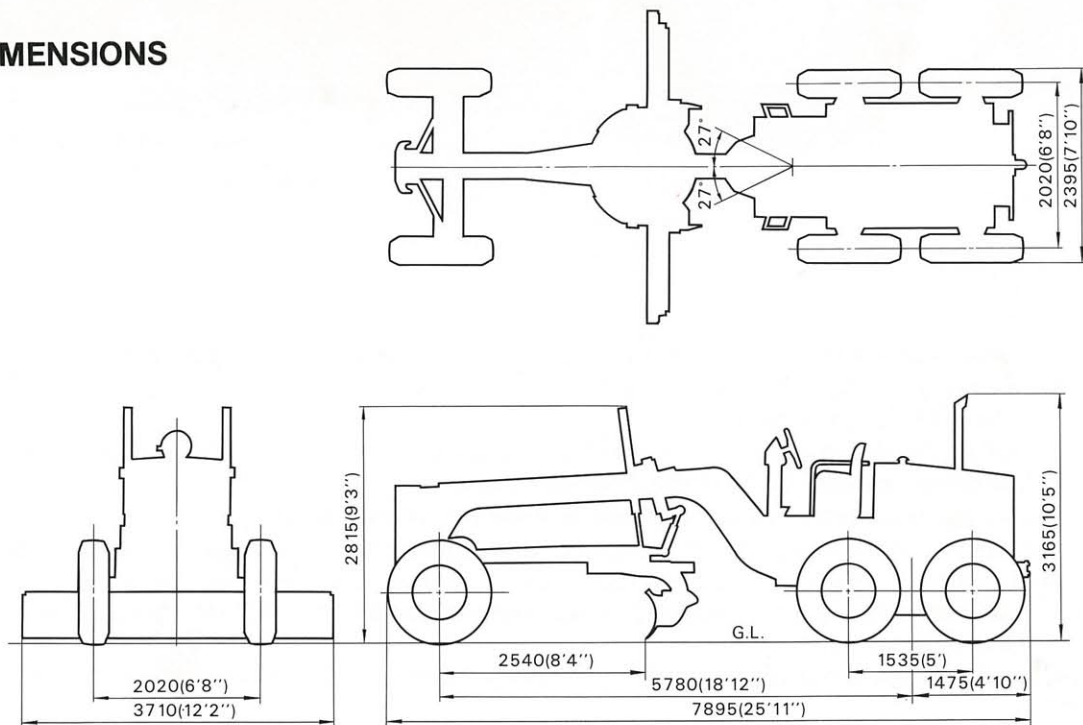

Ground clearance 365 mm (1' 2")

Attachment and optional equipment

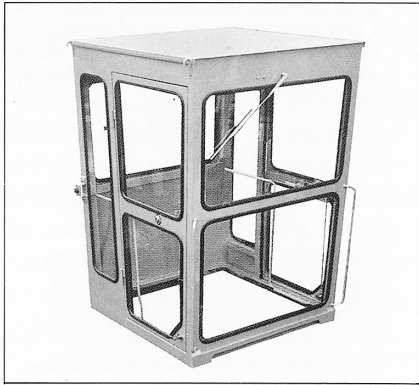

Steel cab:

Additional weight . . . 310 kg (685 lb)
 Installed height . . . 3335 mm (10'11")

ROPS/FOPS: Meets ISO 3471 ROPS
 and ISO 3449 FOPS standard.

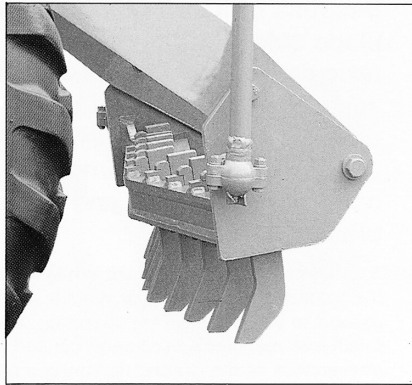

Scarifier: This attachment digs up hard ground, like asphalt, old pavement and frozen surfaces, which are not removable by the blade. The number of teeth can be changed according to ground hardness.

Type . . . V-type, 2-stage adjustable,
 hydraulically controlled
 Number of teeth 9
 Digging width 1065 mm (3'6")
 Max. lift above ground 340 mm
 (1'1")
 Scarifier base 970 mm
 (3'2")
 Additional weight 660 kg
 (1,455 lb)
 (11 tooth type scarifier is also available)

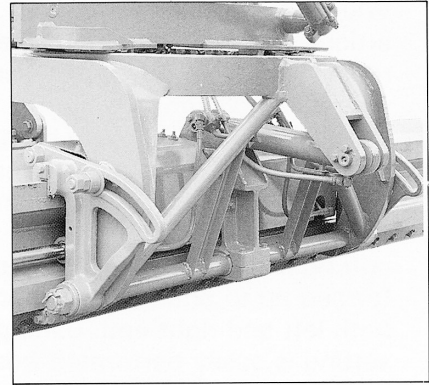

Hydraulic blade tip control: Adjusts the blade-cutting angle according to ground and travel-speed conditions. The angle is freely controlled by a lever operable from the operator's seat.

OPTIONAL EQUIPMENT

LIGHTING SYSTEM: Head lamps. Stop and tail lamps. Turn signal lamps (front and rear). Backup lamps. Working lamps. Licence-plate lamp. Warning beacon.

MIRRORS: Rear-view mirrors. Rear under-view mirror. Inside rear-view mirror.

ENGINE AND POWER TRAIN: Water separator. Large capacity alternator (35 A). Large capacity batteries (110 Ah). Application for dusty and sandy terrain (air cleaner extension, brushless alternator with hardened pulley, starting switch cover). Engine side covers. Rear side covers (for batteries). Air compressor (for tire inflation). Transmission-underguard. No-spin differential. Suction type fan. Additional fuel filter.

TIRES: 13.00-24-10PR, 13.00-24-12PR, 14.00-24-10PR, 14.00-24-12PR, 15.50-25-12PR traction type tubed or tubeless tires.

OPERATOR'S COMPARTMENT: ROPS cab. ROPS canopy. Steel cab. Canopy. Heater/defroster. Windshield wiper. Room lamp. Ash tray/cigar lighter. Seat belt.

METERS AND GAUGES: Speedometer. Engine oil pressure gauge. Fuel level gauge. Ammeter.

WORK EQUIPMENT: Scarifier (9 tooth or 11 tooth type). Front blade. Hydraulic blade tip control. 13' blade. 14' blade.

OTHERS: Front hydraulic piping covers. Double electric horn. Vandalism protection kit (fuel tank, radiator and hydraulic tank cap). Backup buzzer. Backup alarm. Fire extinguisher. Hydraulic jack.

This specification sheet may contain attachments and optional equipment that are not available in your area. Please consult your local Komatsu distributor for those items you may require. Materials and specifications are subject to change without notice.

KOMATSU