

KOMATSU®

GD655-5

HORSEPOWER
Gross: 165 kW 221 HP @ 2100 rpm
Net: 163 kW 218 HP @ 2100 rpm

OPERATING WEIGHT
15495 kg 34,160 lb

BLADE LENGTH
3.71 m 12 ft

ecot3

GD
655

MOTOR GRADER



Photo may include optional equipment.

WALK-AROUND

The New Transmission Includes a Non-stall Function,

a great improvement on the conventional reputable GD655-3, now realizing smoother operation at low speed.
See page 5.

Economical Fuel Consumption by Two Mode Operation

Decreased by 20% compared with Komatsu's conventional model typical test data.
See page 4.

Operator Friendly Cab

(Excellent visibility, low operation noise)
See pages 8 and 9.

Excellent Operator Environment

- Environment friendly Komatsu SAA6D107E-1 engine complies with EPA Tier 3, EU Stage 3A emission.
See page 4.
- Excellent visibility of the moldboard and front by the hexangular cab with front Y pillar and rear layout side pillar.
See page 9.
- Low operating noise
The dynamic noise is lowered significantly compared with the GD655-3.
See page 8.

Economy Features

- Selectable working mode, <P mode> and <E mode>
See page 4.
- Operator can choose <Auto mode> or <Manual mode>.
See page 5.



HORSEPOWER

Gross: 165 kW 221 HP @ 2100 rpm

Net: 163 kW 218 HP @ 2100 rpm

OPERATING WEIGHT

15495 kg 34,160 lb

BLADE LENGTH

3.71 m 12 ft

Excellent Performance

- Smooth operation without the engine stalling at low speed and maximize productivity
See page 5.
- Excellent blade controllability with multifunctional control valves with float and PCV (Pilot Check Valve)
See page 6.
- Aggressive moldboard angles are possible with a long wheel base.
See page 6.

***Easy Serviceability***

- Easy radiator cleaning with a reversing fan
See page 7.
- Easy fueling from the ground level
See page 7.



Photo may include optional equipment.

ECOLOGY FEATURES

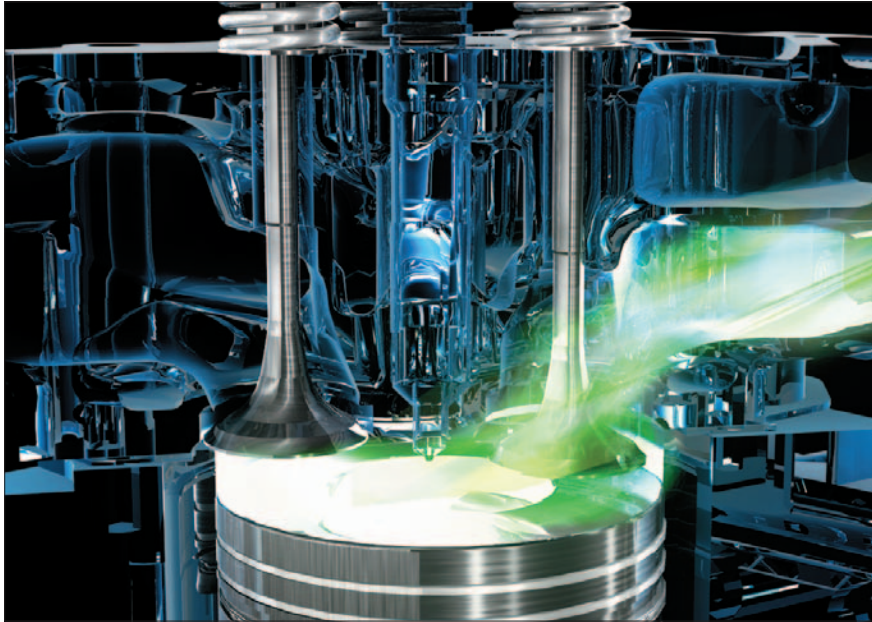

Komatsu Technology



Komatsu develops and produces all major components, such as engines, electronics and hydraulic components in house. Since all components can be matched, efficiencies are increased achieving high levels of productivity and ecology. With this "Komatsu Technology", and through customer feedback, Komatsu is achieving great advancements in technology. The result is a new generation of high performance and environment friendly machines.

High Performance SAA6D107E-1 Komatsu Engine

Electronic heavy duty common rail fuel injection system provides optimum combustion of fuel. This system also provides fast throttle response to match the machine's powerful tractive effort and fast hydraulic response.

NET: 163kW 218HP

Low Emission Engine

This engine is EPA Tier 3 emission regulation and EU Stage 3A emissions certified, without sacrificing power or machine productivity.

Hydraulic Driven and Auto Reversing Cooling Fan

Reduce power loss in case of low temperature and reduce engine noise.

Outstanding Fuel Economy

A significant reduction in fuel consumption is achieved by the control of the engine speed.

Fuel consumption decreased by 20%
(compared with GD655-3 typical test data)

2 Mode 3 Stage VHPC

The system allows selection of the appropriate mode between two modes <P mode> or <E mode> according to each working condition. The mode is easily selected with a switch in the operator's cab.

• **P mode**

Greater productivity can be attained by taking full advantage of high output power. It is appropriate for job sites where the motor grader meets high resistance.

• **E mode**

This mode is selected for maximum economy and lighter work applications.

This feature provides the appropriate power and better fuel consumption.

	kW (HP)			
	P		E	
	AUTO	MANU.	AUTO	MANU.
F1	134 (180)	134 (180)	108 (145)	108 (145)
F2				
F3				
F4	149 (200)	149 (200)	134 (180)	134 (180)
F5				
F6				
F7	163 (218)	163 (218)	149 (200)	149 (200)
F8				
R1	134 (180)	134 (180)	108 (145)	108 (145)
R2				
R3	149 (200)	149 (200)	134 (180)	134 (180)
R4				

DUAL MODE TRANSMISSION

Converter Drive: Designed to Provide Power and Performance

Komatsu Power Shift Transmission

is designed and built specifically for Komatsu graders. The transmission provides on-the-go, full power shifting as well as inching capability and automatic shifting in the higher ranges.

Lock-up Torque Converter (Auto Mode)

or direct drive (manual mode), the operator chooses the optimum transmission set-up for the job at hand. If power for tough grading or low speed fine control is required, the operator can select the auto mode. With the torque converter, the operator has tremendous tractive effort and control. More importantly, you can achieve fine control at low speed without shifting or using an inching pedal. Auto mode is available in gears 1-8. If high transport speed or high speed for snowremoval is needed, the operator can select manual drive. The operator has the best of both worlds.

Gear Selections

Eight forward speeds and four reverse speeds give the operator a wide operating range. With four gear when in auto mode, shifting is automatic in speeds five through eight. The operator sets the maximum gear for operation and the transmission then shift automatically between gears four through eight up to the operator selected maximum gear.

		Position of gear shift lever																
		F-1	F-2	F-3	F-4	F-5	F-6	F-7	F-8	R-1	R-2	R-3	R-4					
AUTO MODE	Gear speed	F-1	○								○							
		F-2		○									○					
		F-3			○									○				
		F-4				○									○			
		F-5					○									○		
		F-6						○									○	
		F-7							○									○
		F-8								○								
MANUAL MODE		●	●	●	●	●	●	●										

- : In lockup state (torque converter is not in use)
- ◎ : As the machine speed increases, torque converter state changes to lockup state.
- : In torque converter state
- | : Automatic gear shift

Electronic Transmission Control

produces smooth shifting, which enables the operator to maintain a uniform grading surface if shifting is required. Smooth shifts also extend the life of the transmission by placing less stress on transmission clutches. A single lever controls direction, speed and parking brake.



Low Effort Inching Pedal

gives the operator precise control of machine movement. This is especially important for operators who have previous experience with operating a manual mode motor grader.

Superior Transmission with a New Function

Combination of manual mode and auto mode is very effective for avoiding engine stalling which leads to low speed smooth operation.

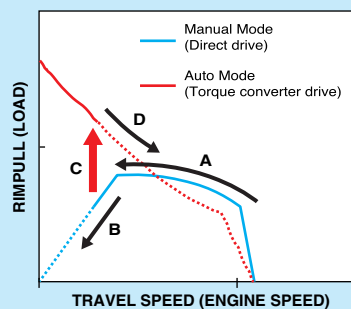

- A If the load increases, the engine speed will down
- B If the load increases further, the engine may stall
- C Just before the engine stall, it automatically changes to auto mode (with torque converter) to avoid stalling
- D When the load decreases and travel speed has recovered, it automatically returns to manual mode

Electronic Overspeed Protection

helps prevent engine and transmission damage from premature downshifting and grade-induced overspeeding.

ADVANCED CONTROL FEATURES

Power on Demand

Normally, the variable displacement pump idles at low output. When it senses a load requirement, the pump supplies quick flow and pressure to match the demand. The result is less hydraulic system heat, quick response and lower fuel consumption. The bottom line is greater efficiency.



Implement Control Valves

Designed and built by Komatsu specifically for motor graders. The valves are direct acting and provide outstanding operator "feel" and predictable system response for precise implement control. To help maintain exact blade settings, lock valves are built into the hydraulic circuits. Relief valves are also incorporated into selected circuits to protect the cylinders from over-pressurization.

Low Operating Effort

Implement controls are designed to reduce operator fatigue. They feature short lever throws and effort in both directions. Properly spaced control levers and short lever throws allow the operator to use multiple controls with one hand.

Balanced Flow

When the operator uses several controls at the same time, flow is proportional to ensure several implements can operate simultaneously.

Constant Implement Speed

Implement speed is constant regardless of engine speed because of the large pump output and proportional flow control function.

Versatile Moldboard Geometry

Komatsu graders feature a versatile moldboard geometry. Save time and money when pulling ditches by throwing the windrow to the right, not into the roadway - without narrowing the road bed. It's made possible by Komatsu's extraordinary reach and aggressive blade angle. Ample clearance between the heel of the blade and main frame, even with the toe sharply angled down.

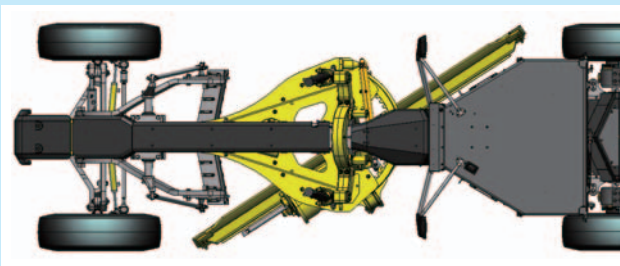

Aggressive moldboard angle

Blade Angle

A long wheel base allows the operator to obtain an aggressive moldboard angle. This large blade angle permits material to roll more freely along the blade, which reduces power requirements. This is particularly helpful in dry soil or clay or for snow and ice removal.

Rugged Construction

The A-frame drawbar is U-shape welded construction. A one-piece forged circle is built to stand up to high stress loads. To reduce wear, teeth are induction hardened in the front 180 deg. of the circle. For maximum support, the circle is secured to the drawbar by six support shoes.

Optional Protection System

Blade Lift Accumulators absorb shocks when the moldboard contacts immovable objects. This option is especially useful in rough grading and rocky areas. It provides precious control while allowing relief from vertical impact loads. This option is most useful in applications where hidden objects are frequently encountered.

MAINTENANCE FEATURES

Superior Serviceability

Easy Access to Service Areas

- Large hinged lockable doors are standard and provide easy access to the engine and radiator service points. Spin-on filters can be changed quickly.
- The fuse panel is located in the cab. Circuits and fuse sizes are clearly identified.
- The tandem oil check point is conveniently located at the end of the tandem.
- The service meter is located in the electronic monitoring system.
- Refueling from the ground is easy.
- Engine oil, hydraulic oil and coolant drains are in the place maintained easily.

Easy Radiator Cleaning with a Reversing Fan

Dust stuck to radiator and cooler fin is blown off with reversal of the hydraulic drive fan.

Power Train Components

With a modular design, you can remove the engine, transmission or final drives independently for quick service.

Character Display is Easy to See

During normal operation, the service meter/odometer is displayed in this area. If an abnormality or machine overload occurs, or if machine maintenance and inspection are required, action codes appear on the display to allow the operator to take appropriate action.

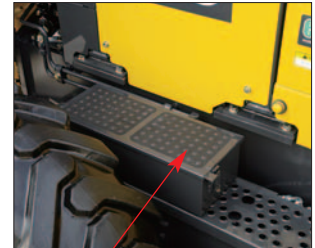
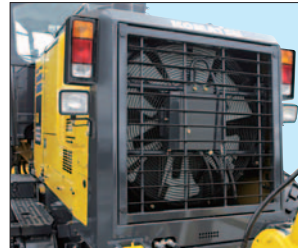

Tool Box



Spin-on Transmission Filter



Adjustment-free Oil Disc Brakes

Komatsu designs and builds multiple-disc brakes that are completely sealed and adjustment-free. The brakes are immersed in oil, hydraulically actuated, and are located at each tandem wheel to eliminate brake loads on the power train and to facilitate servicing. A fully hydraulic brake system eliminates problems associated with air systems. The large braking surface provides dependable braking capability and increased life before a rebuild is required.

Friendly Environment

The engine and transmission are rubber-mounted to transmit less engine noise and vibration to the operator and extend component life. A lead-free aluminum core is used for the radiator to comply with global environmental requirements.

Disconnect Switch

For inspection and maintenance, the batteries can be disconnected with this switch when repairing the machine or checking batteries.

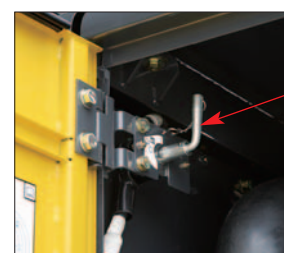

Disconnect Switch

WORKING ENVIRONMENT

A Comfortable Houseroom of Class's Greatest Wide Cab



Operator ear dynamic noise level : 74 dB
(ISO 6396)

Roomy Interior

Extra leg and foot room create a spacious, open cab. The cab includes built-in storage space for personal items such as a lunch box, cup holder, and a coat hook.

Suspension Seat

The seat features fold-up armrests and a retractable seat belt. The seat follows the contour of the body and can be easily adjusted for optimal support and comfort.

Electric Throttle Control

The RPM mode select switch allows the operator to perfectly match the working condition by selecting between three modes: Auto, Off and Manual. The engine speed set by throttle switch is temporarily cancelled when operating the brake/acceleration pedal at Auto mode.

Electronic Monitoring System

Electronic monitoring system monitors important machine systems and provides the operator with a warning if an abnormality occurs.

Adjustable Control Console

The control console is adjustable backward and forward to facilitate entry and exit from the cab. The steering wheel also tilts to the operators preference.

Air Conditioner

Well-positioned air conditioning vents keep the operator comfortable through a wide range of outside conditions.

Safety Machine

Cab is low profile enclosed ROPS/FOPS.
(SAE J1040, J2311)



ROPS (Roll-Over Protective Structure) Cab
(Equipped with defroster and intermittent wiper)



Excellent Visibility from cab

Excellent Visibility

Exceptional visibility by hexangular cab with front Y shape pillar and rear layout side pillar (**patent pending**) helps increase operator confidence and productivity in all grader applications. The well positioned blade linkage provides an unobstructed view of the moldboard and front tires. The tapered engine hood provides good visibility to the rear of the machine, especially the rear ripper.



SPECIFICATIONS



ENGINE

Model..... KOMATSU SAA6D107E-1
 Type Water-cooled,4-cycle,direct injection
 Aspiration Turbocharged and air to air aftercooled
 Number of cylinders 6
 Bore **107 mm** 4.21"
 Stroke..... **124 mm** 4.88"
 Piston displacement..... **6.69 ltr** 408 in³
 Gross horsepower (Manual mode)
 P-mode
 Gear 1-3 **136 kW** 183 HP@2000 rpm
 Gear 4-6 **151 kW** 203 HP@2000 rpm
 Gear 7-8 **165 kW** 221 HP@2100 rpm
 E-mode
 Gear 1-3 **110 kW** 148 HP@2000 rpm
 Gear 4-6 **136 kW** 183 HP@2000 rpm
 Gear 7-8 **151 kW** 203 HP@2000 rpm
 Net flywheel horsepower* (Manual mode)
 P-mode
 Gear 1-3 **134 kW** 180 HP@2000 rpm
 Gear 4-6 **149 kW** 200 HP@2000 rpm
 Gear 7-8 **163 kW** 218 HP@2100 rpm
 E-mode
 Gear 1-3 **108 kW** 145 HP@2000 rpm
 Gear 4-6 **134 kW** 180 HP@2000 rpm
 Gear 7-8 **149 kW** 200 HP@2000 rpm
 Max. torque **941 Nm** 96.0 kg.m 694 lb.ft@1450 rpm
 Torque rise 31 %
 Fan speed..... Max. 1500 rpm
 Air cleaner 2-stage, dry-type
 Electrical..... 24 volt with 60 amp alternator
 Battery 2, low maintenance plus, 12 volt, 1146 cca

* Net flywheel HP output for standard (SAE J1349) including air cleaner, alternator (not charging), water pump, lubricating oil, fuel pump, muffler and fan running at minimum speed.



TRANSMISSION AND TORQUE CONVERTER

Full power shift transmission with integral free wheeling stator torque converter and lock-up.

Speeds (at rated engine speed)

Gear	Forward		Reverse	
1st	3.4 km/h	2.1 mph	4.5 km/h	2.8 mph
2nd	5.0 km/h	3.1 mph	9.2 km/h	5.7 mph
3rd	7.0 km/h	4.3 mph	20.3 km/h	12.6 mph
4th	10.2 km/h	6.3 mph	40.3 km/h	25.0 mph
5th	15.4 km/h	9.6 mph		
6th	22.3 km/h	13.9 mph		
7th	30.6 km/h	19.0 mph		
8th	44.3 km/h	27.5 mph		



TANDEM DRIVE

Oscillating welded box section **520 mm x 202 mm** 1'8" x 8"
 Side wall thickness: Inner **22 mm** 0.87"
 Outer **19 mm** 0.75"
 Wheel axle spacing **1525 mm** 5'0"
 Tandem oscillation 11° forward, 13° reverse



FRONT AXLE

Type Solid bar construction welded steel sections
 Ground clearance at pivot **620 mm** 2'0"
 Wheel lean angle, right or left 16°
 Oscillation, total 32°



REAR AXLE

Alloy steel, heat treated, full floating axle with lock/unlock differential.



WHEELS, FRONT AND REAR

Bearings Tapered roller
 Tires 14.00-24, tubeless
 Tire rims (demountable) 9" one-piece rims



STEERING

Hydraulic power steering providing stopped engine steering meeting SAE J53 and J1151.

Minimum turning radius **7.4 m** 24'3"
 Maximum steering range, right or left 49°
 Articulation 25°



BRAKES

Service brake Foot operated, sealed oil disc brakes, hydraulically actuated on four tandem wheels, **13691 cm²** 2122 in² total braking surface
 Parking brake Manually actuated, spring applied, hydraulically released caliper



FRAME

Front Frame Structure -Height **300 mm** 11.8"
 Front Frame Structure -Width **300 mm** 11.8"
 Front Frame Structure -Thickness **14 mm** 0.55"



DRAWBAR

A-shaped, u-section press formed and welded construction for maximum strength with a replaceable drawbar ball.

Drawbar frame **210 x 25 mm** 8.3"x 1"



CIRCLE

Single piece rolled ring forging. Six circle support shoes with replaceable wear surface. Circle teeth hardened on front 180° of circle.

Diameter (outside) **1530 mm** 5'0"
Circle reversing control hydraulic rotation 360°



MOLDBOARD

Hydraulic power shift fabricated from high carbon steel. Includes replaceable metal wear inserts, cutting edge and end bits. Cutting edge and end bits are hardened.

Dimensions **3710 x 645 x 19 mm** 12'2" x 2'1" x 0.75"
Arc radius **329 mm** 1'1"
Cutting edge **152 x 16 mm** 6" x 0.63"



BLADE RANGE

Circle center shift: Right **590 mm** 1'11"
Left **590 mm** 1'11"
Moldboard side shift:
Right **820 mm** 2'8"
Left **820 mm** 2'8"
Maximum shoulder reach outside rear tires (frame straight)
Right **2000 mm** 6'7"
Left **2000 mm** 6'7"
Maximum lift above ground **480 mm** 1'7"
Maximum cutting depth **615 mm** 2'0"
Maximum blade angle, right or left 90°
Blade tip angle 40° forward, 5° backward



HYDRAULICS

Load-sensing closed center hydraulics with variable displacement piston pump. short stroke/low effort direct acting control valves with preselected maximum flow setting to each function. Double acting anti-drift check valves on blade lift, tip, circle shift, articulation, and leaning wheels.

Output **200 ltr/min** 52.8 U.S.gal/min@ 2000 rpm
Standby pressure **3.4 MPa** 35 kg/cm² 500 psi
Maximum system pressure **20.6 MPa** 210 kg/cm² 3,000 psi



INSTRUMENT

Electric monitoring system with diagnostics:

Gauges:

Standard articulation, engine coolant temperature, fuel level, speed meter, T/M shift indicator, engine tachometer torque converter oil temperature

Warning lights/Indicator:

Standard battery charge, brake oil pressure, blade float, brake oil pressure, inching temperature, directional indicator, engine oil pressure, hydraulic oil temperature, heater signal, lift arm lock, parking brake, differential lock, torque converter oil temperature, eco, P mode, fan reverse, rpm set, high beam, working lights

Optional blade accumulator



CAPACITIES (REFILLING)

Fuel tank **416 ltr** 109.9 U.S. gal
Cooling system **24.9 ltr** 6.6 U.S. gal
Crank case **23.1 ltr** 6.1 U.S. gal
Transmission **45 ltr** 11.9 U.S. gal
Final drive **17 ltr** 4.5 U.S. gal
Tandem housing (each) **57 ltr** 15.1 U.S. gal
Hydraulic system **69 ltr** 18.2 U.S. gal
Circle reverse housing **7 ltr** 1.8 U.S. gal



OPERATING WEIGHT (APPROXIMATE)

Includes lubricants, coolant, full fuel tank

Total **15495 kg** 34,160 lb
On rear wheels **11290 kg** 24,890 lb
On front wheels **4205 kg** 9,270 lb

With rear mounted ripper and front push plate:

Total **17425 kg** 38,415 lb
On rear wheels **12385 kg** 27,305 lb
On front wheels **5040 kg** 11,110 lb

With front mounted scarifier:

Total **16140 kg** 35,580 lb
On rear wheels **11370 kg** 25,070 lb
On front wheels **4770 kg** 10,510 lb



DIMENSIONS

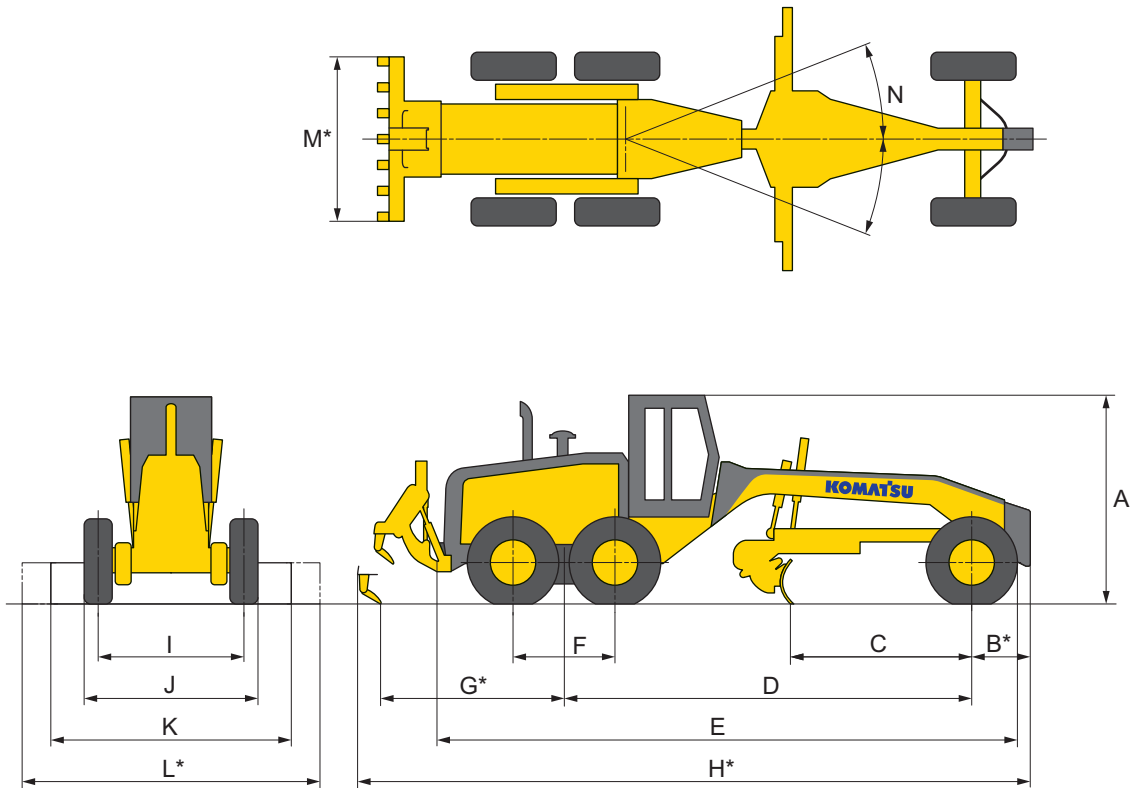

A	Height: Low profile cab:	3200 mm	10'6"
B*	Center of front axle to counterweight (Pusher)	927 mm	3'0"
C	Cutting edge to center of front axle	2580 mm	8'6"
D	Wheel base to center of tandem	6480 mm	21'3"
E	Front tire to rear bumper	9205 mm	30'2"
F	Tandem wheelbase	1525 mm	5'0"
G*	Center of tandem to back of ripper	2780 mm	9'1"
H*	Overall length	10575 mm	34'8"
I	Track of gauge	2060 mm	6'9"
J	Width of tires	2485 mm	8'2"
K	Width of standard moldboard	3710 mm	12'2"
L*	Width of optional moldboard	4320 mm	14'2"
M*	Ripper beam width	2305 mm	7'7"
N	Articulation, left or right	25°	

*optional



STANDARD EQUIPMENT

Engine and Related Items

- Double element air cleaner and dust indicator.
- Engine: Komatsu SAA6D107E-1, EPA Tier 3 certified, turbocharged and air-to-air aftercooled, standard VHPC, 145-218 net horsepower
- Fuel line pre-filter
- Hood-sides for engine compartment
- Air intake extension

Electrical Systems

- Alarm, back-up
- Alternator, 60 amp, 24V
- Battery, extreme duty, 1146 cca each
- Dome light, cab
- Horn, electric
- Lights: back-up, stop, tail, directional, headlights (2 halogen type, front bar mounted)
- Work lamps: front (4), rear (2)
- Speedometer
- Indicators: parking brake, differential lock, blade float, lift arm lock, high beam, eco, engine P mode, cooling fan reverse, rpm set, engine oil pressure, battery charge, brake oil pressure, differential oil temperature

Operator Environment

- Cab: low profile enclosed ROPS/FOPS (SAE J1040, J2311) with safety tinted glass windows with wiper and washer
- Air conditioner (R134a)
- Console, adjustable with instrument panel monitoring system
- Mirrors: interior cab, right and left exterior mirrors
- Seat, deluxe adjustable cloth with retractable seat belt
- Sound suppression, cab and floor mat
- Wipers, front, doors, and rear
- 12V (10A) power port

Power Train

- Dual mode Transmission (8F-4R) power shift, direct drive and torque converter with auto shift
- Axle, rear full floating, planetary type
- Service brakes, fully hydraulic wet disc
- Brake, parking, spring applied, hydraulic release, disc type
- Differential, lock/unlock
- Tires and rims: 14.00-24 (G2) tubeless bias tires on 9" rims (6)

Work Equipment and Hydraulics

- Circle, drawbar mounted, 360° rotation hydraulic blade lift and circle side shift
- Circle slip clutch
- Hydraulic system, closed center, load sensing
- Moldboard: **3710 mm x 645 mm x 19 mm** 12'2" x 2'1" x 0.75" with replaceable end bits, through-hardened cutting edges **152 mm x 16 mm** 6" x 0.63", hydraulic blade side shift and hydraulic tilt with anti-drift check valves. Maximum moldboard angle position 90° right & left
- Steering, full hydraulic with tilt steering wheel plus leaning front wheels and frame articulation w/anti-drift check valves
- 9 section hydraulic control valve
- Blade lift float detent style, LH and RH

Other Standard Equipment

- Painting, Komatsu standard color scheme
- Steps and handrails, rear, right, and left side
- Vandalism protection includes lockable access to fuel tank, battery cover, and engine side covers
- Tool box with lock
- Fuel tank, ground level access
- Battery disconnect switch



OPTIONAL EQUIPMENT

- Accumulators, anti-shock for blade lift
- 10 section hydraulic control valve
- Cab mount work lamps (4)
- General toolkit
- Pre-cleaner, Turbo II
- Pusher plate, additional
- Additional heater
- AM/FM radio
- Moldboard,
 - 3710 mm x 645 mm x 25 mm** 12'2" x 2'1" x 0.98"
 - 4320 mm x 645 mm x 19 mm** 14'2" x 2'1" x 0.75"
 - 4320 mm x 645 mm x 25 mm** 14'2" x 2'1" x 0.98"
 with replaceable end bits, through-hardened cutting edges **152 mm x 16 mm** 6" x 0.63"
- Tires and rims: 17.5R25 tubeless radial tires on 13" rims (6)
- Front blade
- Ripper, assembly, rear mounted
- Ripper shanks and points, 2 additional
- Scarifier, assembly, 11-shank type
- Scarifier, shanks and points (9) for ripper
- Warning light, amber colored rotating beacon, cab roof mounted
- Alternator, 90 amp, 24V



Ripper

Standard equipment may vary for each country, and this specification sheet may contain attachments and optional equipment that are not available in your area. Please consult your Komatsu distributor for detailed information.

KOMATSU[®]