

# KOMATSU®

## GD705-5

### HORSEPOWER

Gross: 194 kW 260 HP/1950min<sup>-1</sup>

Net: 186 kW 250 HP/1950min<sup>-1</sup>

### OPERATING WEIGHT

19300 kg (with ripper 22150 kg)

### BLADE LENGTH

4.32 m

ecot3

GD  
705

MOTOR GRADER



Photos may include optional equipment.

# WALK-AROUND

## ***PRODUCTIVITY & ECONOMY FEATURES***

- Higher productivity & lower fuel consumption
- The lock-up torque converter transmission with electronic control
- Increased cooling capacity and new arrangement of cooling system
- Longest wheelbase & short turning radius
- Power on demand
- Multifunction control valve

See page 4 and 5.

## ***EASY MAINTENANCE & SAFETY FEATURES***

- Machine monitor
- Easy access to service areas
- Power train components
- Disconnect switch
- Hydraulically controlled wet multiple-disc brake
- Circle drive slip clutch

See page 10.



**HORSEPOWER**

Gross: 194 kW 260 HP/1950min<sup>-1</sup>  
 Net: 186 kW 250 HP/1950min<sup>-1</sup>

**OPERATING WEIGHT**

19300 kg (with ripper 22150 kg)

**BLADE LENGTH**

4.32 m

**INFORMATION & COMMUNICATION TECHNOLOGY**

- KOMTRAX

See page 11.

**OPERATOR COMFORT**

- Excellent visibility
- ROPS cab
- Low noise
- Suspension seat
- Adopted DC12V electrical outlet (optional)
- Electronic monitoring system
- Adjust control console
- Electric throttle control
- Air conditioner
- Roomy interior

See page 6 and 7.

**ECOLOGY FEATURES**

- High performance Komatsu SAA6D114E-3 engine
- Engine power mode selection system
- Circumference dynamic noise
- Environmental impact reduction
- Double seal cylinder

See page 8 and 9.

# PRODUCTIVITY & ECONOMY FEATURES

## Higher productivity & Lower fuel consumption

New Hydraulic variable displacement piston pump for reducing pressure loss, improvements in transmission and axles for improving energy saving, and the sophisticated electronic control of the engine operation to achieve optimal energy efficiency, all combined, realize maximum 5% better work rate and 5% better fuel consumption in the field compared with the GD705A-4.

Earthwork amount maximum **5.0% UP (P Mode)**

Fuel consumption maximum  
**5.0% reduction (P Mode)**  
**15.0% reduction (E Mode)**

\* Compared with the GD705A-4. Fuel consumption varies depending on job conditions.



## The lock-up torque converter transmission with electronic control

is designed and built specifically for Komatsu graders. The transmission provides on-the-go, full power shifting as well as inching capability and automatic shifting in the higher ranges.

### 1) Transmission mode selection system

#### • Auto mode

Torque converter in F1-F4 gears, easy 2 pedal (accelerator and brake) operation, easy to operate the motor grader, maximum productivity at any application, easy traveling and high maneuverability with automatic gear shifting.

Torque converter produces over 2 times the torque when starting, which allows you to start from 4th gear. The F-5 through F-8 automatic range can be used for smooth and easy operating.

#### • Manual mode

Direct drive in all gears, works the same way as conventional power shift machine, constant machine speed, more economical operation.

### 2) Engine stall prevention function

If the load increases further, the engine may stall on manual mode. The engine stall prevention function will work just before the engine stall, it automatically changes to auto mode (with torque converter) to avoid stalling.

### 3) Electronic over-speed protection

Helps prevent engine and transmission damage from premature downshifting and grade-induced overspeeding.

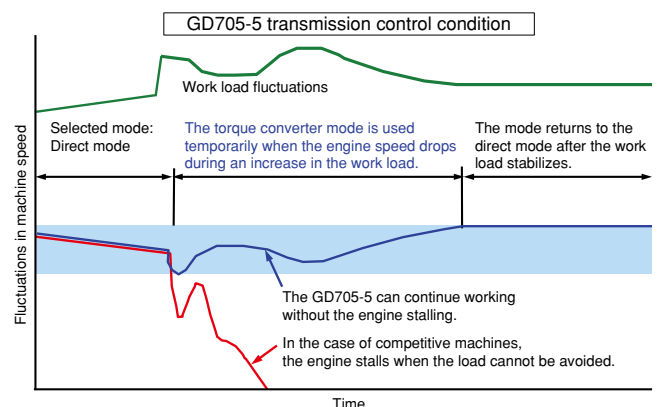
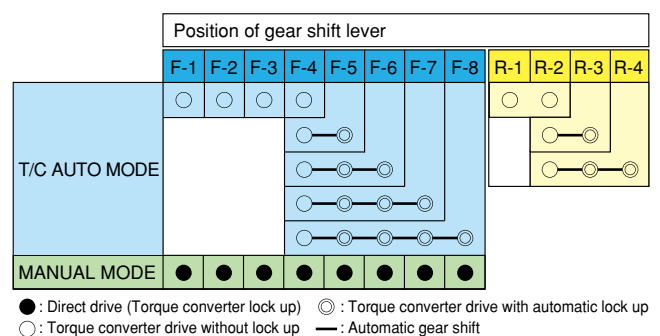



#### 4) Smooth shift with the torque converter curves

during lock-up shifting will protect operator and the equipment such as engine and transmission by minimize the shift shock.



#### Increased cooling capacity

The arrangement of the cooling system is redesigned and the hydraulic driven cooling fan provide an air flow rate enough for the engine heat dissipation.

#### The longest wheelbase & short turning radius

The longest wheel base enable high leveling performance with a long blade and easier to set the blade position. On the other hand, the minimum radius is set short, and excellent maneuverability.



#### Power on demand

Normally, the variable displacement pump idles at low output. When it senses a load requirement, the pump supplies quick flow and pressure to match the demand. The result is less hydraulic system heat, quick response and lower fuel consumption.

#### Control valve

Komatsu Multifunctional Control Valve with CLSS (Closed Load Sensing System) Hydraulic System enable the constant cylinder speed, excellent simultaneous operation ability, fine control.

##### 1) Low operating effort

Implement controls are designed to reduce operator fatigue. They feature short lever throws and effort in both directions. Properly spaced control levers and short lever throws allow the operator to use multiple controls with one hand.

##### 2) Balanced flow

When the operator uses several controls at the same time, flow is proportional to ensure several implements can operate simultaneously.

##### 3) Constant implement speed

Implement speed is constant regardless of engine speed because of the large pump output and proportional flow control function.

# OPERATOR COMFORT



## Visibility

Excellent visibility by hexangular cab with front Y shape pillar and rear layout side pillar boost operator's confidence and productivity in all grader applications. Well-positioned blade linkage provides an unobstructed view of the moldboard and front tires. The tapered engine hood provides good visibility to the rear of the machine, especially the rear ripper.

## ROPS cab

Cab is low profile enclosed ROPS/FOPS. (ISO 3471/ISO 3449)

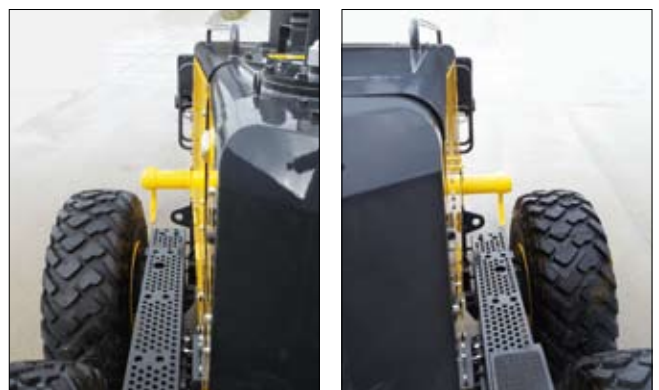

Rear (ripper) view

### Low noise

New hydraulically driven fan and redesigned layout of the cooling system achieve a low noise level.

**Operator's ear dynamic  
noise level (ISO6396) 78 dB (A)**

### Suspension seat

The suspension, fabric covered seat which is adjustable to the operator's weight is provided as standard.

The suspension seat dampens vibrations transmitted from the machine and reduces operator fatigue.

The seat features fold-up armrests and a retractable seat belt.



### Adopted DC12V electrical outlet (optional)

12 volt DC outlets is included in the operator's cab.

### Electronic monitoring system

Electronic monitoring system monitors important machine systems and provides the operator with a warning if an abnormality occurs.

### Adjustable control console

The control console is adjustable backward and forward to facilitate entry and exit from the cab. The steering wheel also tilts to the operators preference.

### Electric throttle control

The RPM mode select switch allows the operator to perfectly match the working condition by selecting between three modes: Auto, Off and Manual. The engine speed set by throttle switch is temporarily cancelled when operating the brake/acceleration pedal at Auto mode.



### Air conditioner

Well-positioned air conditioning vents keep the operator comfortable through a wide range of outside conditions.



### Roomy interior

The cab includes built-in storage space for personal items such as a lunch box, coffee cup, and a coat hook.



# ECOLOGY FEATURES



## Komatsu technology



Komatsu develops and produces all major components, such as engines, electronics and hydraulic components, in house. With this “Komatsu Technology,” and adding customer feedback, Komatsu is achieving great advancement in technology.

To achieve both high levels of productivity and economical performance, Komatsu has developed the main components with a total control system. The result is a new generation of high performance and the arrangement of the cooling system is redesigned and environment friendly machines.

## High performance engine

Powerful turbocharged and air-to-air aftercooled Komatsu SAA6D114E-3 engine provides 186 kW 250 HP. This engine realizes high power with low fuel consumption by Common Rail Injection system (CRI), and thus it delivers higher work speeds with high horsepower. In addition, high torque at low speed, impressive acceleration, and low fuel consumption ensure maximum productivity.

This engine is EPA Tier 3 and EU Stage 3A emissions equivalent.

## Engine power mode selection system

The system allows selection of the appropriate mode between two modes <P mode> or <E mode> according to each working condition. The mode is easily selected with a switch in the operator’s cab.

### • P mode

Greater productivity can be attained by taking full advantage of high output power. It is appropriate for job sites where the motor grader meets high resistance.

### • E mode

This mode is selected for maximum economy and lighter work applications. This feature provides the appropriate power and better fuel consumption.



unit: kW(HP)

	P mode	E mode
F1	150 (201)	120 (161)
F2		
F3	165 (221)	150 (201)
F4		
F5		
F6	186 (250)	165 (221)
F7		
F8		
R1	150 (201)	120 (161)
R2		
R3	165 (221)	150 (201)
R4		

**Circumference dynamic noise**

The dynamic circumference noise is lowered significantly to 7dB(A) compared with the conventional GD705A-4 by various kind of countermeasures like the hydraulic driven cooling fan ,the variable displacement pump and etc.

**Circumference dynamic noise level (ISO6395) 109 dB (A)**



Hydraulic driven cooling fan

**Environmental impact reduction**

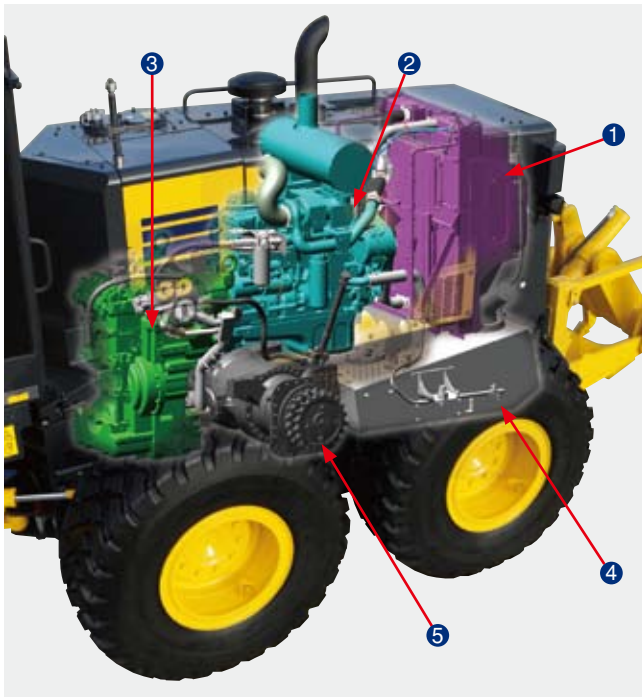

**1 Cooling system**

Hexavalent chromium abolition on the Aluminum radiator.  
The hydraulic driven cooling fan reduce the Operator ears and Circumference dynamic noise.

**2 Engine**

EPA Tier 3 and EU Stage 3A emissions equivalent.  
Low fuel consumption with Sophisticated electronic engine control.

**3 Transmission**

Energy is saved by the efficient work with automatic / manual selection for according to the work situation.

**4 Fuel tank**

Tank layout for prevent the spread of sound.

**5 Final drive**

Energy saving improvements in axles.

**Double seal cylinder (Blade side shift cylinder)**

A double-seal design is used for the blade side shift cylinder, which is installed near the ground, and thus susceptible to damage by dirt.

Environmentally friendly by preventing oil leakage from the cylinder.

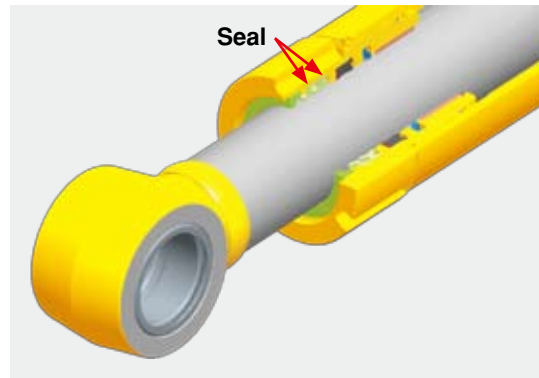

# EASY MAINTENANCE & SAFETY FEATURES

## Machine monitor

The machine monitor displays various machine information and allows for various settings of the machine. Displays maintenance information, operation records, etc. By using the switch panel, you can display various user menus on the LCD unit screen and perform the settings of the machine.

### • Clear Character Display

During normal operation, the service meter/odometer is displayed in this area. If an abnormality or machine overload occurs, or if machine maintenance and inspection are required, action codes appear on the display to allow the operator to take appropriate action.



- ① Gear position
- ② Speed meter
- ③ ECO indicator
- ④ Power mode indicator
- ⑤ Character display
  - Service meter
  - Odometer
  - Maintenance information
  - Error code
  - Fuel consumption information

## Superior serviceability

### Easy access to service areas

- Large hinged lockable doors are standard and provide easy access to the engine and radiator service points. Spin-on filters can be changed quickly.
- The fuse panel is located in the cab. Circuits and fuse sizes are clearly identified.
- The tandem oil check point is conveniently located at the end of the tandem.
- The service meter is located in the electronic monitoring system.
- Easy refueling from the ground.
- Engine oil, hydraulic oil and coolant drains, are located near the ground with easy maintenance.

### Power train components

With a modular design, you can remove the engine, transmission or final drives independently for quick service.

### Disconnect switch

For inspection and maintenance, the batteries can be disconnected with this switch when repairing the machine or checking batteries.

### Hydraulically controlled wet multiple-disc brake

Komatsu designs and builds multiple-disc brakes that are completely sealed and adjustment-free. The brakes are immersed in oil, hydraulically actuated, and are located at each tandem wheel to eliminate brake loads on the power train and to facilitate servicing. A fully hydraulic brake system eliminates problems associated with air systems. The large braking surface provides dependable braking capability and increased life before a rebuild is required.

### Circle drive slip clutch

Protects the drawbar, circle and moldboard from shock loads when the blade encounters an immovable object. At excessive load on the moldboard, it can reduce the load on the machine by the clutch portion slips.



**Tool box**

**Ground refueling**

# INFORMATION & COMMUNICATION TECHNOLOGY



## *KOMTRAX assists customer's equipment management and contributes to fuel cost cutting*

### Equipment management support

KOMTRAX terminal installed on your machine collects and sends information such as machine location, working record, machine conditions, etc. using wireless communication. You can review the KOMTRAX data remotely via the online application. KOMTRAX not only gives you the information on your machine, but also the convenience of managing your fleet on the Web.



Machine monitoring



Monthly SMR record

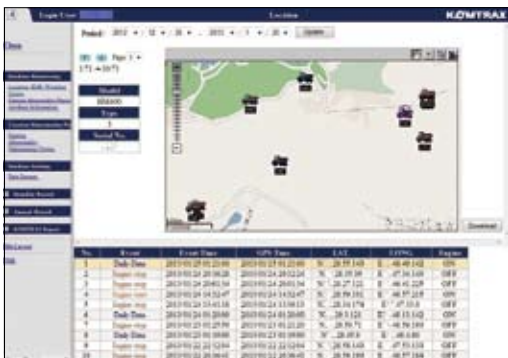

Location

Date	Working Hours	Working Mile	Working Volume	Fuel	Water Usage
20101024	00:00	0.00	0.00	0.00	0.00
20101023	00:00	0.00	0.00	0.00	0.00
20101022	00:00	0.00	0.00	0.00	0.00
20101021	00:00	0.00	0.00	0.00	0.00
20101020	00:00	0.00	0.00	0.00	0.00
20101019	00:00	0.00	0.00	0.00	0.00
20101018	00:00	0.00	0.00	0.00	0.00
20101017	00:00	0.00	0.00	0.00	0.00
20101016	00:00	0.00	0.00	0.00	0.00
20101015	00:00	0.00	0.00	0.00	0.00

Monthly working record

\*KOMTRAX may be unable to be used in some countries or the areas. Please consult your Komatsu distributor.

- Location information / Operational status
- Service Meter
- Engine lock
- Gauge level
- Error / Caution
- Time for replacement
- Load information
- Average gas mileage



# SPECIFICATIONS



## ENGINE

Model ..... KOMATSU SAA6D114E-3  
 Type ..... Water-cooled, 4-cycle, direct injection  
 Aspiration ..... Turbocharged and air to air aftercooled  
 Number of cylinders ..... 6  
 Bore ..... 114 mm  
 Stroke ..... 135 mm  
 Piston displacement ..... 8.27 L  
 Gross horsepower (Manual mode)  
 P-mode  
 Gear 1-2 ..... 158 kW 212 HP/1950 min<sup>-1</sup>  
 Gear 3-5 ..... 173 kW 232 HP/1950 min<sup>-1</sup>  
 Gear 6-8 ..... 194 kW 260 HP/1950 min<sup>-1</sup>  
 E-mode  
 Gear 1-2 ..... 128 kW 172 HP/1950 min<sup>-1</sup>  
 Gear 3-5 ..... 158 kW 212 HP/1950 min<sup>-1</sup>  
 Gear 6-8 ..... 173 kW 232 HP/1950 min<sup>-1</sup>  
 Net horsepower\* (Manual mode)  
 P-mode  
 Gear 1-2 ..... 150 kW 201 HP/1950 min<sup>-1</sup>  
 Gear 3-5 ..... 165 kW 221 HP/1950 min<sup>-1</sup>  
 Gear 6-8 ..... 186 kW 250 HP/1950 min<sup>-1</sup>  
 E-mode  
 Gear 1-2 ..... 120 kW 161 HP/1950 min<sup>-1</sup>  
 Gear 3-5 ..... 150 kW 201 HP/1950 min<sup>-1</sup>  
 Gear 6-8 ..... 165 kW 221 HP/1950 min<sup>-1</sup>  
 Max. torque ..... 1130 Nm 115 kgm/1450 min<sup>-1</sup>  
 Torque rise ..... 19 %  
 Fan speed ..... Max. 1700 min<sup>-1</sup>  
 Air cleaner ..... 2-stage, dry-type

\* Net horsepower output for standard (SAE J1349) including air cleaner, alternator (not charging), water pump, lubricating oil, fuel pump, muffler and fan running at minimum speed.

EPA Tier 3 and EU Stage 3A emissions equivalent.



## TRANSMISSION AND TORQUE CONVERTER

Full power shift transmission with integral free wheeling stator torque converter and lock-up.

**Speeds** (at rated engine speed)

Gear	Forward	Reverse
1st	4.0 km/h	4.5 km/h
2nd	5.6 km/h	8.8 km/h
3rd	7.7 km/h	17.4 km/h
4th	10.9 km/h	34.1 km/h
5th	15.3 km/h	—
6th	21.6 km/h	—
7th	30.0 km/h	—
8th	42.5 km/h	—



## TANDEM DRIVE

Oscillating welded box section ..... 567 mm x 226 mm  
 Side wall thickness: Inner ..... 22 mm  
 Outer ..... 19 mm  
 Wheel axle spacing ..... 1680 mm  
 Tandem oscillation ..... 15° forward, 15° reverse



## FRONT AXLE

Type ..... Solid bar construction welded steel sections  
 Ground clearance at pivot ..... 670 mm  
 Wheel lean angle, right or left ..... 15°  
 Oscillation, total ..... 32°



## REAR AXLE

Alloy steel, heat treated, full floating axle with lock/unlock differential.



## WHEELS, FRONT AND REAR

Bearings ..... Tapered roller  
 Tires ..... 16.00-24, with tube  
 Tire rims (demountable) ..... 10.00 VA x 24 (three pieces rims)



## STEERING

Hydraulic power steering providing stopped engine steering meeting ISO 5010.  
 Minimum turning radius ..... 7.6 m  
 Maximum steering range, right or left ..... 50°  
 Articulation ..... 27°



## BRAKES

Service brake ..... Foot operated, sealed oil disc brakes, hydraulically actuated on four tandem wheels.  
 Parking brake ..... Manually actuated, spring applied, hydraulically released caliper.



## FRAME

Front Frame Structure  
 Height ..... 339 mm  
 Width ..... 300 mm  
 Side ..... 32 mm  
 Upper, Lower ..... 32 mm



## DRAWBAR

A-shaped, u-section press formed and welded construction for maximum strength with a replaceable drawbar ball.  
 Drawbar frame ..... 235 mm x 25 mm



## CIRCLE

Single piece rolled ring forging. Six circle support shoes with replaceable wear surface. Circle teeth hardened on front 180° of circle.  
 Diameter (outside) ..... 1550 mm  
 Circle reversing control hydraulic rotation ..... 360°



**MOLDBOARD**

Hydraulic power shift fabricated from high carbon steel. Includes replaceable metal wear inserts, cutting edge and end bits. Cutting edge and end bits are hardened.  
 Dimensions . . . . . 4320 mm x 700 mm x 25 mm  
 Arc radius . . . . . 414 mm  
 Cutting edge . . . . . 203 mm x 16 mm  
 Replaceable/Reversible side edges . . . . 280 mm x 620 mm x 13 mm



**BLADE RANGE**

Moldboard side shift:  
 Right . . . . . 1251 mm  
 Left . . . . . 1250 mm  
 Maximum shoulder reach outside rear tires (frame straight)  
 Right . . . . . 2360 mm  
 Left . . . . . 2290 mm  
 Maximum lift above ground . . . . . 450 mm  
 Maximum cutting depth . . . . . 710 mm  
 Maximum blade angle, right or left . . . . 90°  
 Blade tip angle . . . . . 45° forward, 7° backward



**HYDRAULICS**

Load-sensing closed center hydraulics with variable displacement piston pump. Short stroke/low effort direct acting control valves with preselected maximum flow setting to each function. Double acting anti-drift check valves on blade lift, tip, circle shift, articulation, and leaning wheels.  
 Output (at engine rated rpm) . . . . . 165L/min  
 Standby pressure . . . . . 3.4 MPa 35 kg/cm<sup>2</sup>  
 Maximum system pressure . . . . . 24.5Mpa 250kg/cm<sup>2</sup>



**INSTRUMENT**

Electric monitoring system with diagnostics:  
 Gauges:  
 Standard . . . . . articulation, engine coolant temperature, fuel level, speed meter, T/M shift indicator, engine tachometer torque converter oil temperature  
 Warning lights/Indicator:  
 Standard . . . . . battery charge, brake oil pressure, inching temperature, directional indicator, engine oil pressure, hydraulic oil temperature, heater signal, lift arm lock, parking brake, differential lock, torque converter oil temperature, eco, P mode, rpm set, high beam, working lights  
 Optional . . . . . blade accumulator



**CAPACITIES (REFILLING)**

Fuel tank . . . . . 408 L  
 Cooling system . . . . . 24.5 L  
 Crank case . . . . . 27 L  
 Transmission . . . . . 62 L  
 Final drive . . . . . 11.5 L  
 Tandem housing (each) . . . . . 79 L  
 Hydraulic system . . . . . 69 L  
 Circle reverse housing . . . . . 10 L



**OPERATING WEIGHT (APPROXIMATE)**

Includes lubricants, coolant, full fuel tank  
 Total . . . . . 19300 kg  
 On rear wheels . . . . . 13800 kg  
 On front wheels . . . . . 5500 kg  
 With rear mounted ripper and front push plate:  
 Total . . . . . 22150 kg  
 On rear wheels . . . . . 16100 kg  
 On front wheels . . . . . 6050 kg

# GD705-5 MOTOR GRADER



## DIMENSIONS

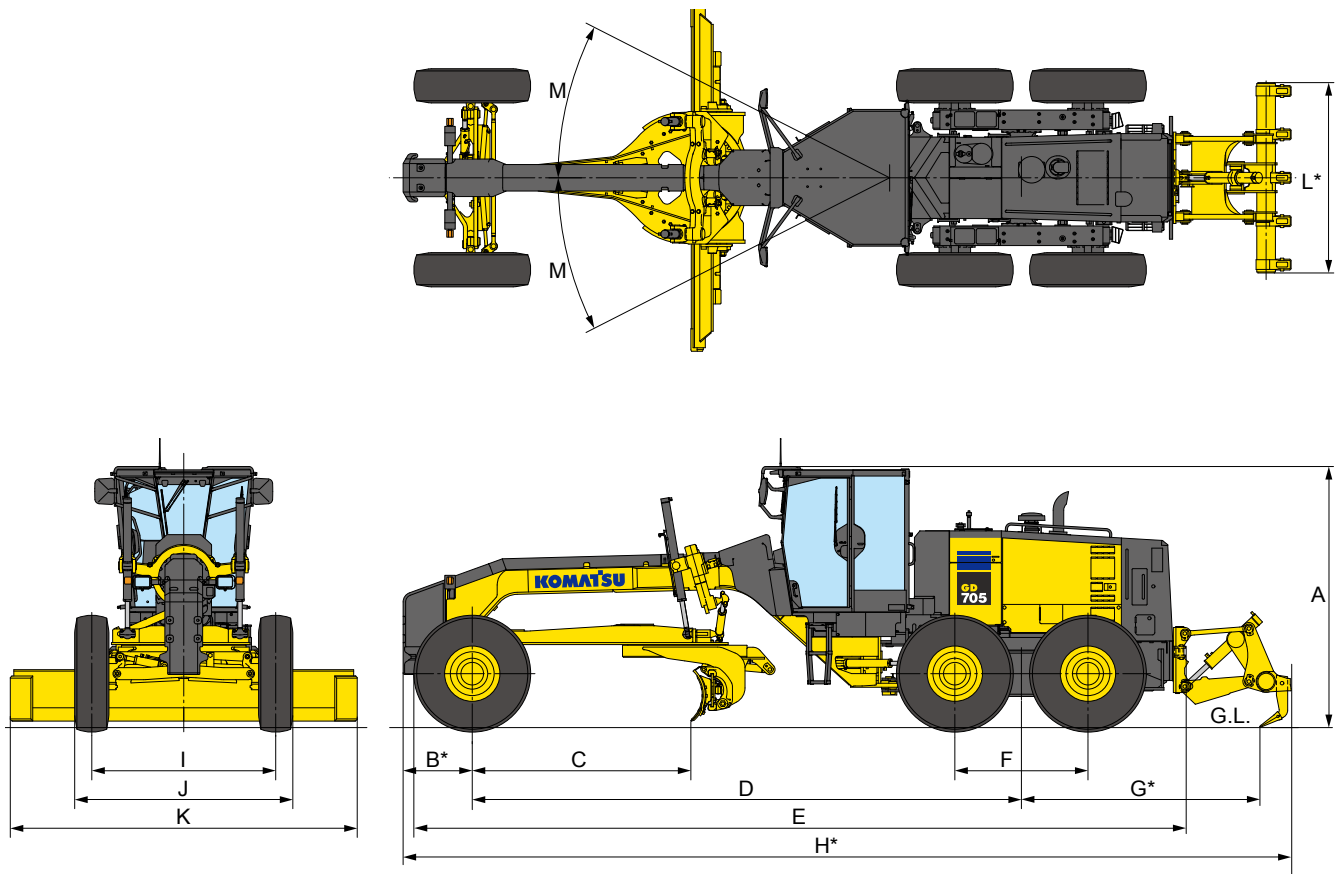

A	Height: Low profile cab	3260 mm
B*	Center of front axle to counterweight (Pusher)	860 mm
C	Cutting edge to center of front axle	2700 mm
D	Wheel base to center of tandem	6800 mm
E	Front tire to rear bumper	9600 mm
F	Tandem wheelbase	1680 mm
G*	Center of tandem to back of ripper	2955 mm
H*	Overall length	11050 mm
I	Track of gauge	2290 mm
J	Width of tires	2790 mm
K	Width of standard moldboard	4320 mm
L*	Ripper beam width	2366 mm
M	Articulation, left or right	27°

\*optional



## STANDARD EQUIPMENT

**Engine and Related Items**

- Air intake extension
- Double element air cleaner and dust indicator.
- Engine: Komatsu SAA6D114E-3, turbocharged and air-to-air aftercooled, standard VHPC, 201-250 net horsepower
- Fuel prefilter
- Hood-sides for engine compartment

**Electrical Systems**

- Alarm, back-up
- Alternator, 24V/60A
- Battery, 2 x 12V/140Ah
- Dome light, cab
- Horn, electric
- Indicators: parking brake, differential lock, lift arm lock, high beam, eco, engine P mode, rpm set, engine oil pressure, battery charge, brake oil pressure, differential oil temperature
- Lights: back-up, stop, tail, directional, headlights (2 halogen type, front bar mounted)
- Speedometer

**Operator Environment**

- Air conditioner (R134a)
- Cab: low profile enclosed ROPS/FOPS (ISO 3471/ISO 3449) with safety tinted glass windows with wiper and washer
- Cigarette lighter and ashtray
- Console, adjustable with instrument panel monitoring system
- Mirrors: interior cab, right and left exterior mirrors
- Seat, deluxe adjustable cloth with retractable seat belt
- Sound suppression, cab and floor mat
- Wipers, front, doors, and rear

**Power Train**

- Axle, rear full floating, planetary type
- Brake, parking, spring applied, hydraulic release, disc type
- Differential, lock/unlock
- Dual mode Transmission (F8-R4) power shift, direct drive and torque converter with auto shift, engine stall prevention function
- Service brakes, fully hydraulic wet disc
- Tires and rims: 16.00-24 (G-2) tubed bias tires on 10" rims (6)

**Work Equipment and Hydraulics**

- 9 section hydraulic control valve
- Circle, drawbar mounted, 360° rotation hydraulic blade lift and circle side shift
- Circle slip clutch
- Hydraulic system, closed center, load sensing
- Moldboard: 4320 mm x 700 mm x 25 mm with replaceable end bits, through-hardened cutting edges 203 mm x 16 mm, hydraulic blade side shift and hydraulic tilt with anti-drift check valves. Maximum moldboard angle position 90° right & left
- Steering, full hydraulic with tilt steering wheel plus leaning front wheels and frame articulation w/anti-drift check valves

**Other Standard Equipment**

- Battery disconnect switch
- Fuel tank, ground level access
- General toolkit
- Painting, Komatsu standard color scheme
- Steps and handrails, rear, right, and left side
- Tool box with lock
- Vandalism protection includes lockable access to fuel tank, battery cover, and engine side covers



## OPTIONAL EQUIPMENT

- 10 section hydraulic control valve
- 12V (10A) power port
- Accumulators, anti-shock for blade lift
- Alternator, 24V/90A
- AM/FM radio
- Cab mount work lamps (4)
- Extinguisher
- Fog light (front bar mounted)
- Pre-cleaner
- Pusher plate, additional
- Rear under view mirror

- Ripper, assembly, rear mounted
  - Ripper depth maximum 380 mm
  - Ripper shank holders 5
  - Penetration force 11,200 kg (at rear weight 16,100 kg)



- Ripper shanks and points, 2 additional
- Scarifier, assembly, 11-shank type
- Starter, 11 kW
- Tires and rims: 20.5R25 tubeless radial tires on 17" rims (6)
- Transmission under guard
- Warning light, amber colored rotating beacon, cab roof mounted
- Work lamps: front (4), rear (2)

**KOMATSU**<sup>®</sup>