

# KOMATSU®

## GD755-5R

### HORSEPOWER

Gross: 216 kW 290 HP / 2000 min<sup>-1</sup>

Net: 213 kW 286 HP / 2000 min<sup>-1</sup>

### OPERATING WEIGHT

21650 kg (with ripper 24380 kg)

### BLADE LENGTH

4.32 m

**GD**  
**755**

MOTOR GRADER



Photos may include optional equipment.

# WALK-AROUND

## ***The New Transmission Includes a Non-stall Function,***

adopting the conventional reputable GD655-5, now realizing smoother operation at low speed.

See page 5.

## ***Operator Friendly Cab***

(Excellent visibility, low operation noise)

See pages 8 and 9.

## ***Excellent Operator Environment***

- Komatsu SAA6D125E-5 engine is U.S. EPA Tier 2 and EU Stage 2 emissions equivalent.

See page 4.

- Excellent visibility of the moldboard and front by a new quadrangle cab.

See page 9.

- Low operating noise  
The dynamic noise is lowered drastically compared with the GD705A-4.

See page 8.

## ***Economy Features***

- Operator can choose <Auto mode> or <Manual mode>.

See page 5.



**HORSEPOWER**Gross: 216 kW 290 HP / 2000 min<sup>-1</sup>Net: 213 kW 286 HP / 2000 min<sup>-1</sup>**OPERATING WEIGHT**

21650 kg (with ripper 24380 kg)

**BLADE LENGTH**

4.32 m

***Excellent Performance***

- Smooth operation without the engine stalling at low speed and maximize productivity  
See page 5.
- Excellent blade controllability with multifunctional control valves with float and Pilot Check Valve  
See page 6.
- Aggressive moldboard angles are possible with a long wheel base.  
See page 6.

***Easy Serviceability***

- Easy fueling from the ground level  
See page 7.

# ECOLOGY FEATURES

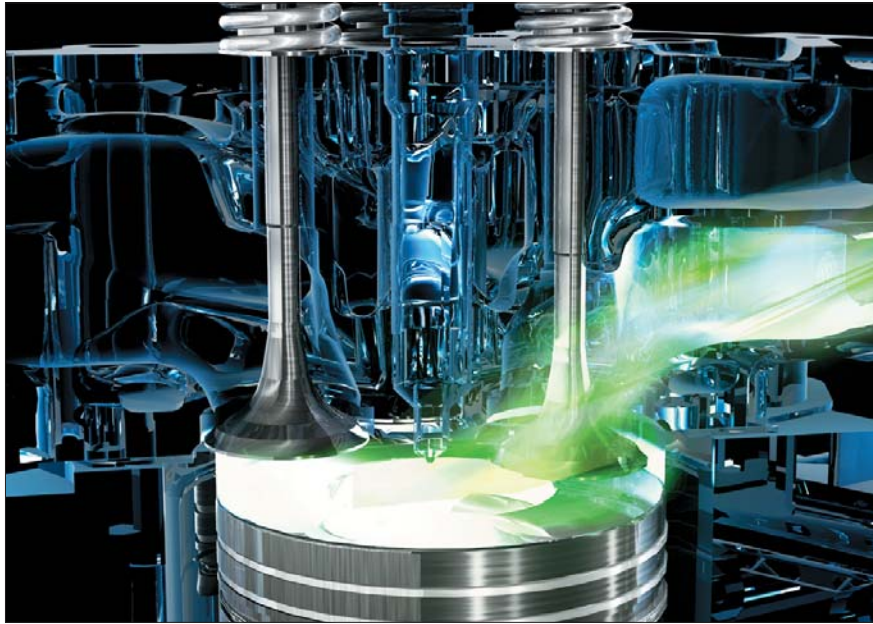

### Komatsu Technology

Komatsu develops and produces all major components, such as engines, electronics and hydraulic components in house.

Since all components can be matched, efficiencies are increased achieving high levels of productivity and ecology. With this "Komatsu Technology", and through customer feedback, Komatsu is achieving great advancements in technology.

The result is a new generation of high performance and environment friendly machines.

### High Performance and Low Emission SAA6D125E-5 Komatsu Engine

This engine equipped with an electronically controlled high-pressure fuel injection system (Common rail), air-cooled aftercooler, and high-efficiency turbocharger. This engine is U.S. EPA Tier 2 and EU Stage 2 emissions equivalent.

**NET: 213kW 286HP**

### Hydraulic Driven Cooling Fan

Reduce power loss in case of low temperature and reduce engine noise.

### Outstanding Fuel Economy

A significant reduction in fuel consumption is achieved by the control of the engine speed.

### 4 Stage Variable Horsepower Control

This machine is powered by the strong Komatsu SAA6D125E-5 engine. The engine features Variable Horsepower Control that allows an extra burst of power delivery when the engine operates in medium to high speed ranges.

On job-sites where the machine is allowed to operate within medium to high speeds, the machine can perform exceptionally well. In addition, since the machine can move speedily between job sites, work efficiency is improved.

		kW (HP)				
		AUTO	MANU.		AUTO	MANU.
F1	171 (229)	171 (229)	R1			
F2			R2			
F3			R3			
F4	209 (280)	209 (280)	R4	209 (280)	209 (280)	
F5			R5			
F6			R6			
F7	213 (286)	213 (286)	R7			
F8	212 (284)	212 (284)	R8	206 (276)	206 (276)	

# DUAL MODE TRANSMISSION

## Converter Drive: Designed to Provide Power and Performance

### Komatsu Power Shift Transmission

is designed and built specifically for Komatsu graders. The transmission provides on-the-go, full power shifting as well as inching capability and automatic shifting in the higher ranges.

### Lock-up Torque Converter (Auto Mode)

or direct drive (Manual mode), the operator chooses the optimum transmission set-up for the job at hand. If power for tough grading or low speed fine control is required, the operator can select the auto mode. With the torque converter, the operator has tremendous tractive effort and control. More importantly, you can achieve fine control at low speed without shifting or using an inching pedal. Auto mode is available in gears 1-8. If high transport speed or high speed for snow removal is needed, the operator can select manual drive. The operator has the best of both worlds.

### Gear Selections

Eight forward speeds and eight reverse speeds give the operator a wide operating range. With four gear when in auto mode, shifting is automatic in speeds five through eight. The operator sets the maximum gear for operation and the transmission then shift automatically between gears four though eight up to the operator selected maximum gear.

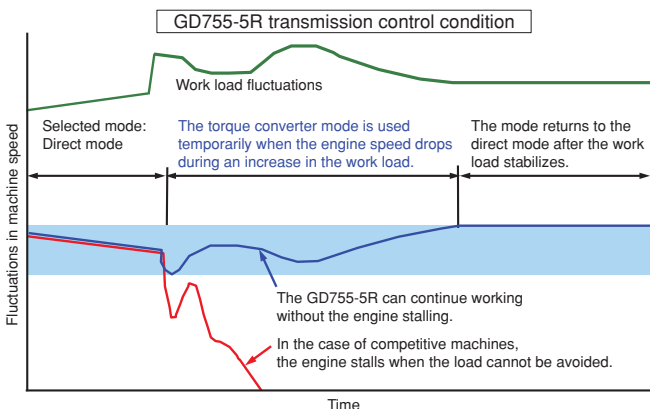
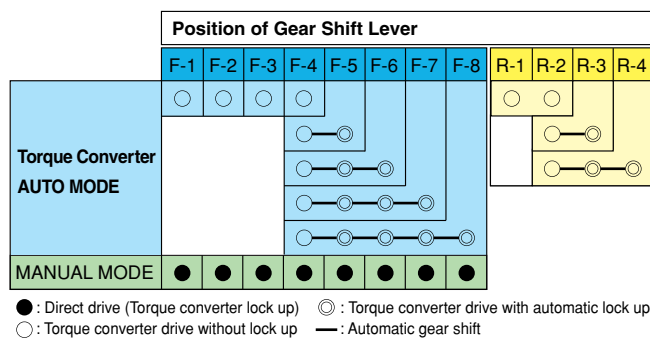

### Electronic Transmission Control

produces smooth shifting, which enables the operator to maintain a uniform grading surface if shifting is required. Smooth shifts also extend the life of the transmission by placing less stress on transmission clutches. A single lever controls direction, speed and parking brake.



### Electronic Overspeed Protection

helps prevent engine and transmission damage from premature downshifting and grade-induced overspeeding.

### Low Effort Inching Pedal

gives the operator precise control of machine movement. This is especially important for operators who have previous experience with operating a manual mode motor grader.

# ADVANCED CONTROL FEATURES

## Power on Demand

Normally, the variable displacement pump idles at low output. When it senses a load requirement, the pump supplies quick flow and pressure to match the demand. The result is less hydraulic system heat, quick response and lower fuel consumption. The bottom line is greater efficiency.

## Constant Implement Speed

Implement speed is constant regardless of engine speed because of the large pump output and proportional flow control function.



## Implement Control Valves

Designed and built by Komatsu specifically for motor graders. The valves are direct acting and provide outstanding operator "feel" and predictable system response for precise implement control. To help maintain exact blade settings, lock valves are built into the hydraulic circuits. Relief valves are also incorporated into selected circuits to protect the cylinders from over-pressurization.

## Low Operating Effort

Implement controls are designed to reduce operator fatigue. They feature short lever throws and effort in both directions. Properly spaced control levers and short lever throws allow the operator to use multiple controls with one hand.

## Balanced Flow

When the operator uses several controls at the same time, flow is proportional to ensure several implements can operate simultaneously.

## *Versatile Moldboard Geometry and Excellent Blade Controllability*

Komatsu graders feature a versatile moldboard geometry. Save time and money when pulling ditches by throwing the windrow to the right, not into the roadway - without narrowing the road bed. It's made possible by Komatsu's extraordinary reach and aggressive blade angle. Ample clearance between the heel of the blade and main frame, even with the toe sharply angled down.

Excellent blade controllability with multifunctional control valves with float and Pilot Check Valve is realized.

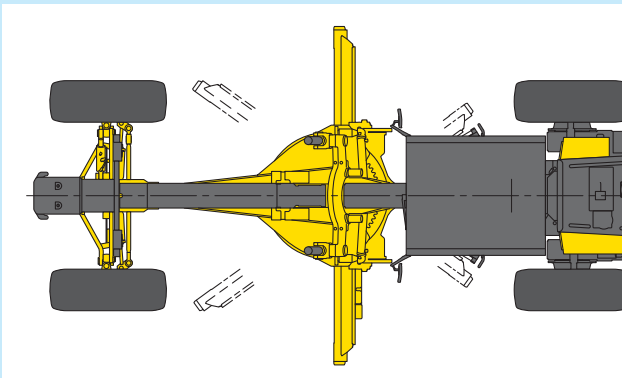

**Aggressive moldboard angle**

## Blade Angle

A long wheel base allows the operator to obtain an aggressive moldboard angle. This large blade angle permits material to roll more freely along the blade, which reduces power requirements. This is particularly helpful in dry soil or clay or for snow and ice removal.

## Rugged Construction

The A-frame drawbar is U-shape welded construction. A one-piece forged circle is built to stand up to high stress loads. To reduce wear, teeth are induction hardened in the front 180 deg. of the circle. For maximum support, the circle is secured to the drawbar by six support shoes.

## Optional Protection System

**Blade lift accumulators** absorb shocks when the moldboard contacts immovable objects. This option is especially useful in rough grading and rocky areas. It provides precious control while allowing relief from vertical impact loads. This option is most useful in applications where hidden objects are frequently encountered.

# MAINTENANCE FEATURES

## Superior Serviceability

### Easy Access to Service Areas

- Large hinged lockable doors are standard and provide easy access to the engine and radiator service points. Spin-on filters can be changed quickly.
- The fuse panel is located in the cab. Circuits and fuse sizes are clearly identified.
- The tandem oil check point is conveniently located at the end of the tandem.
- The service meter is located in the electronic monitoring system.
- Refueling from the ground is easy.
- Engine oil, hydraulic oil and coolant drains are in the place maintained easily.

### Power Train Components

With a modular design, you can remove the engine, transmission or final drives independently for quick service.

### Adjustment-free Oil Disc Brakes

Komatsu designs and builds multiple-disc brakes that are completely sealed and adjustment-free. The brakes are immersed in oil, hydraulically actuated, and are located at each tandem wheel to eliminate brake loads on the power train and to facilitate servicing. A fully hydraulic brake system eliminates problems associated with air systems. The large braking surface provides dependable braking capability and increased life before a rebuild is required.



### Character Display Is Easy to See

During normal operation, the service meter/odometer is displayed in this area. If an abnormality or machine overload occurs, or if machine maintenance and inspection are required, action codes appear on the display to allow the operator to take appropriate action.

### Friendly Environment

The engine and transmission are rubber-mounted to transmit less engine noise and vibration to the operator and extend component life. A lead-free aluminum core is used for the radiator to comply with global environmental requirements.



Tool box



Spin-on transmission filter



Refueling from the ground

# WORKING ENVIRONMENT

## A Comfortable Houserom of Class's Greatest Wide Cab



### Roomy Interior

Extra leg and foot room create a spacious, open cab. The cab includes built-in storage space for personal items such as a lunch box, cup holder, and a coat hook.

### Suspension Seat

The seat features fold-up armrests and a retractable seat belt. The seat follows the contour of the body and can be easily adjusted for optimal support and comfort.

### Electric Throttle Control

The RPM mode select switch allows the operator to perfectly match the working condition by selecting between three modes: Auto, Off and Manual. The engine speed set by throttle switch is temporarily cancelled when operating the brake/acceleration pedal at Auto mode.

### Electronic Monitoring System

Electronic monitoring system monitors important machine systems and provides the operator with a warning if an abnormality occurs.

### Low Operating Noise

By changing the location of the equipments, the dynamic noise is lowered drastically compared with the GD705A-4.

### Adjustable Control Console

The control console is adjustable backward and forward to facilitate entry and exit from the cab. The steering wheel also tilts to the operators preference.

### Air Conditioner (A/C)

Well-positioned air conditioning vents keep the operator comfortable through a wide range of outside conditions.

### Safety Machine

Cab is low profile enclosed ROPS/FOPS (ISO 3471 / ISO 3449).



**ROPS (ISO 3471) Cab**  
(Equipped with defroster and intermittent wiper)



Excellent visibility from cab

### Excellent Visibility

Exceptional visibility by quadrangle cab with front pillar and rear layout side pillar helps increase operator confidence and productivity in all grader applications. The well positioned blade linkage provides an unobstructed view of the moldboard and front tires. The tapered engine hood provides good visibility to the rear of the machine, especially the rear ripper.



# SPECIFICATIONS



## ENGINE

Model..... KOMATSU SAA6D125E-5  
 Type..... Water-cooled,4-cycle,direct injection  
 Aspiration..... Turbocharged and air to air aftercooled  
 Number of cylinders..... 6  
 Bore..... 125 mm  
 Stroke..... 150 mm  
 Piston displacement..... 11.04 L  
 Gross horsepower  
   Gear 1..... 174 kW 233 HP / 2000 min<sup>-1</sup>  
   Gear 2-6..... 212 kW 284 HP / 1700 min<sup>-1</sup>  
   Gear 7..... 216 kW 290 HP / 2000 min<sup>-1</sup>  
   Gear 8..... 215 kW 288 HP / 1850 min<sup>-1</sup>  
 Net horsepower\*  
   Gear 1..... 171 kW 229 HP / 2000 min<sup>-1</sup>  
   Gear 2-6..... 209 kW 280 HP / 1700 min<sup>-1</sup>  
   Gear 7..... 213 kW 286 HP / 2000 min<sup>-1</sup>  
   Gear 8..... 212 kW 284 HP / 1850 min<sup>-1</sup>  
 Max. torque..... 1298 N·m / 1400 min<sup>-1</sup>  
 Torque rise..... 28.0 %  
 Fan speed..... Max. 1650 min<sup>-1</sup>  
 Air cleaner..... 2-stage, dry-type  
 Electrical..... 24 V with 75 A alternator  
 Battery..... 2, low maintenance plus, 12 V, 930 cca

\* : Net horsepower output for standard (SAE J1349) including air cleaner, alternator (Not charging), water lubricating oil, fuel pump, muffler and fan running at minimum speed.  
 U.S. EPA Tier 2 and EU Stage 2 emissions equivalent.



## TRANSMISSION AND TORQUE CONVERTER

Full power shift transmission with integral free wheeling stator torque converter and lock-up.

**Speeds** (At rated engine speed)

Gear	Forward	Reverse
1st	5.1 km/h	5.7 km/h
2nd	7.9 km/h	8.9 km/h
3rd	9.5 km/h	10.7 km/h
4th	12.1 km/h	13.6 km/h
5th	14.9 km/h	Auto
6th	19.1 km/h	Auto
7th	29.2 km/h	Auto
8th	45.0 km/h	43.6 km/h



## TANDEM DRIVE

Oscillating welded box section..... 658 mm x 258 mm  
 Side wall thickness: Inner..... 22 mm  
                                   Outer..... 19 mm  
 Wheel axle spacing..... 1653 mm  
 Tandem oscillation..... 15° forward & reverse



## FRONT AXLE

Type..... Solid bar construction welded steel sections  
 Ground clearance at pivot..... 625 mm  
 Wheel lean angle, right or left..... 16°  
 Oscillation, total..... 32°



## REAR AXLE

Alloy steel, heat treated, full floating axle with lock/unlock differential.



## WHEELS, FRONT AND REAR

Bearings..... Tapered roller  
 Tires..... 16.00-24 (G2), tubeless  
 Tire rims (Demountable)..... 10.00 VA x 24



## STEERING

Hydraulic power steering providing stopped engine steering meeting ISO 5010.

Minimum turning radius..... 7.7 m  
 Maximum steering range, right or left..... 50°  
 Articulation..... 27°, left or right



## BRAKES

Service brake..... Foot operated, sealed oil disc brakes, hydraulically actuated in four tandem wheels, 20007 cm<sup>2</sup> total braking surface  
 Parking brake..... Manually actuated, spring applied, hydraulically released caliper with transmission interlock



## FRAME

Front Frame Structure -Height..... 350 mm  
 Front Frame Structure -Width..... 300 mm  
 Front Frame Structure -Thickness..... 14 mm



## DRAWBAR

A-shaped, u-section press formed and welded construction for maximum strength with a replaceable drawbar ball.

Drawbar frame . . . . . 220 x 19 mm



## CIRCLE

Single piece rolled ring forging. Six circle support shoes with replaceable wear surface. Circle teeth hardened on front 180° of circle.

Diameter (Outside) . . . . . 1614 mm  
Circle reversing control hydraulic rotation . . . . . 360°



## MOLDBOARD

Hydraulic power shift fabricated from high carbon steel. Includes replaceable side edge. Side edge is through hardened.

Dimensions . . . . . 4320 x 700 x 25 mm  
Arc radius . . . . . 414 mm  
Cutting edge . . . . . 203 x 16 mm  
Replaceable/reversible side edges . . . . . 280 x 620 x 13 mm



## BLADE RANGE

Circle center shift: Right . . . . . 590 mm  
Left . . . . . 590 mm  
Moldboard side shift:  
Right . . . . . 965 mm  
Left . . . . . 966 mm  
Maximum shoulder reach outside rear tires (Frame straight)  
Right . . . . . 2360 mm  
Left . . . . . 2290 mm  
Maximum lift above ground . . . . . 452 mm  
Maximum cutting depth . . . . . 720 mm  
Maximum blade angle, right or left . . . . . 90°  
Blade tip angle . . . . . 45° forward, 7° backward



## HYDRAULICS

Load-sensing closed center hydraulics with variable displacement piston pump. short stroke/low effort direct acting control valves with preselected maximum flow setting to each function. Double acting anti-drift check valves on blade lift, tip, circle shift, articulation, and leaning wheels.

Output (At engine rated rpm) . . . . . 193 L/min  
Standby pressure . . . . . 3.4 MPa  
Maximum system pressure . . . . . 20.6 MPa



## INSTRUMENT

Electric monitoring system with diagnostics:

Gauges:

Standard . . . . . articulation, engine coolant temperature, fuel level, speed meter, transmission shift indicator, engine tachometer, torque converter oil temperature

Warning lights/Indicator:

Standard . . . . . battery charge, brake oil pressure, inching temperature, directional indicator, engine oil pressure, hydraulic oil temperature, heater signal, lift arm lock, parking brake, differential lock and torque converter oil temperature, differential lock, rpm set, creep mode, high beam, working lights

Optional . . . . . blade accumulator



## CAPACITIES (REFILLING)

Fuel tank . . . . . 400 L  
Cooling system . . . . . 38 L  
Crank case . . . . . 38 L  
Transmission . . . . . 50 L  
Final drive . . . . . 21 L  
Tandem housing (Each) . . . . . 107 L  
Hydraulic system . . . . . 51 L  
Circle reverse housing . . . . . 10 L



## OPERATING WEIGHT (APPROXIMATE)

Includes lubricants, coolant, full fuel tank

Total . . . . . 21650 kg  
On rear wheels . . . . . 15165 kg  
On front wheels . . . . . 6485 kg

With rear mounted ripper and front push plate:

Total . . . . . 24380 kg  
On rear wheels . . . . . 17765 kg  
On front wheels . . . . . 6615 kg



## DIMENSIONS

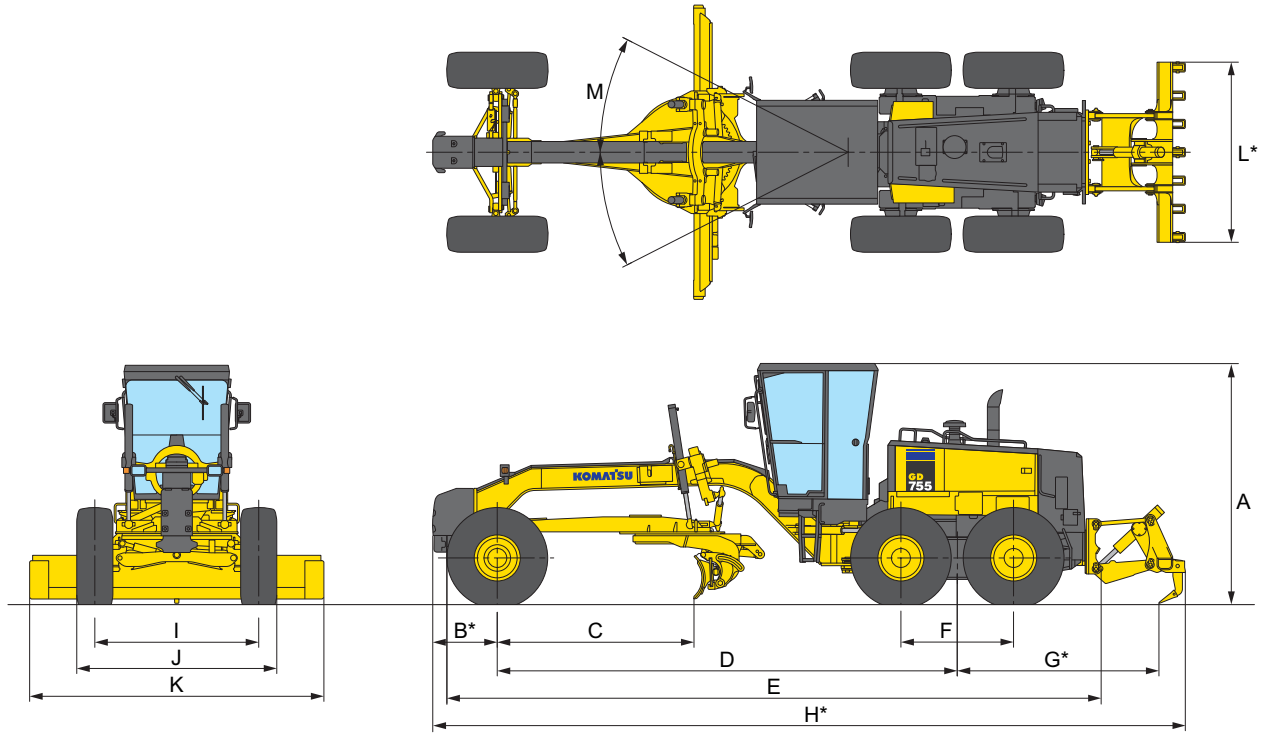

A	Height: Low profile cab	3535 mm
B*	Center of front axle to counterweight (Pusher)	945 mm
C	Cutting edge to center of front axle	2860 mm
D	Wheel base to center of tandem	6750 mm
E	Front tire to rear bumper (Rear hook)	9540 mm
F	Tandem wheelbase	1653 mm
G*	Center of tandem to back of ripper	2955 mm
H*	Overall length	11045 mm
I	Track of gauge	2300 mm
J	Width of tires	2800 mm
K	Width of standard moldboard	4320 mm
L*	Ripper beam width	2645 mm
M	Articulation, left or right	27°

\*Optional



## STANDARD EQUIPMENT

### Engine and Related Items

- Air intake extension
- Double element air cleaner and dust indicator
- Engine: Komatsu SAA6D125E-5, turbocharged and air-to-air aftercooled, standard VHPC, 229-286 net horsepower
- Fuel line pre-filter
- Hood-sides for engine compartment

### Electrical Systems

- Alarm, back-up
- Alternator, 24 V/75 A
- Battery, extreme duty, 930 cca each
- Dome light, cab
- Horn, electric
- Indicators: parking brake, differential high beam, rpm set, engine oil pressure, battery charge, brake oil pressure, transmission system electric circuit monitor, differential oil temperature
- Lights: back-up, stop, tail, directional, headlights
- Speedometer

### Operator Environment

- A/C (R134a) with heater
- Cab: low profile enclosed ROPS/FOPS (ISO 3471 / ISO 3449) with safety tinted glass windows with wiper and washer, electric defroster rear window
- Console, adjustable with instrument panel monitoring system
- Mirrors: interior cab, right and left exterior mirrors
- Seat, deluxe adjustable cloth with retractable seat belt
- Sound suppression, cab and floor mat
- Wipers, front, upper

### Power Train

- Axle, rear full floating, planetary type
- Brake, parking, spring applied, hydraulic release, disc type
- Differential, lock/unlock
- Dual mode transmission (8F-8R) power shift, direct drive and torque converter with auto shift
- Service brakes, fully hydraulic wet disc
- Tires and rims: 16.00-24 (G2) tubeless bias tires on 10" rims (6)

### Work Equipment and Hydraulics

- Circle, drawbar mounted, 360° rotation hydraulic blade lift and circle side shift
  - Circle slip clutch
  - Hydraulic system, closed center, load sensing
  - Moldboard: 4320 mm x 700 mm x 25 mm with replaceable side edge, through hardened cutting edges
  - 280 mm x 620 mm x 13 mm, hydraulic blade side shift and hydraulic tilt with anti-drift check valves. Maximum moldboard angle position 90° right & left
  - Overlay end bits
  - Steering, full hydraulic with tilt steering wheel plus leaning front wheels and frame articulation w/anti-drift check valves
  - 8 section hydraulic control valve
- ### Other Standard Equipment
- Fuel tank, ground level access
  - Painting, Komatsu standard color scheme
  - Steps and handrails, rear, right, and left side
  - Tool box with lock
  - Vandalism protection includes lockable access to fuel tank, hydraulic tank, and engine side covers



## OPTIONAL EQUIPMENT

- Accumulators, anti-shock for blade lift
- AM/FM radio
- Fire extinguisher
- General toolkit
- KOMTRAX wireless monitoring system
- Pre-cleaner, Turbo II
- Pusher plate, additional
- Ripper, assembly, rear mounted
- Ripper shanks and points, 4 additional
- Tires and rims: 20.5R25 tubeless radial tires on 17" rims (6)
- Warning light, amber colored rotating beacon, cab roof mounted
- Water separator
- Wipers, front lower, and rear
- Work lamps: front(2), rear(2)
- 9 section hydraulic control valve



Ripper

Standard equipment may vary for each country, and this specification sheet may contain attachments and optional equipment that are not available in your area. Please consult your Komatsu distributor for detailed information.





**KOMATSU**<sup>®</sup>