

KOMATSU®

HD785-7

HD
785

HORSEPOWER

Gross: 895 kW 1200 HP

Net: 879 kW 1178 HP

RATED GROSS VEHICLE WEIGHT (GVW)

163780 kg



Photos may include optional equipment.

WALK-AROUND





ECOLOGY & ECONOMY

- ▮ Komatsu U.S. EPA Tier 2 Emission Certified Engine
- ▮ Mode Selection System with Variable HorsePower Control (VHPC)

PERFORMANCE

- ▮ Automatic Retard Speed Control (ARSC) as Standard
- ▮ Komatsu Advanced Transmission with Optimum. Modulation Control System (K-ATOMiCS) with Skip Shift Function
- ▮ Synchronous Control of Engine and Transmission
- ▮ Komatsu Traction Control System (KTCS) (Optional)

OPERATOR COMFORT

- ▮ Ergonomically Designed Cab
- ▮ Low Operation Noise
- ▮ Air Suspension Seat (Optional)
- ▮ Tilt-away Steering Column
- ▮ Three-mode Automatic Hydropneumatic Suspension (Optional)
- ▮ Viscous Cab Mounts
- ▮ Electronic Hoist Control
- ▮ Rear view monitor system (Optional)
- ▮ Built-in ROPS/FOPS Cab (ISO 3471/ISO 3449)
- ▮ Secondary Steering and Brake

INFORMATION & COMMUNICATION TECHNOLOGY (ICT)

- ▮ Easy-to-see Instrumental Panel
- ▮ KOMTRAX Plus

RELIABILITY

- ▮ Robust Dump Body Design
- ▮ Payload Meter (PLM)
- ▮ Loading Policy
- ▮ High-rigidity Frame

MAINTENANCE

- ▮ Extended Oil Change Interval
- ▮ Disc Wheels (Flange type rim)
- ▮ Electric Circuit Breakers

HD785-7		
HORSEPOWER	Gross:	895 kW 1200 HP
	Net:	879 kW 1178 HP
RATED GVW		163780 kg

PRODUCTIVITY & ECONOMY

High Performance Komatsu SAA12V140E-3 Engine

This engine delivers faster acceleration and higher travel speeds with high horsepower per ton. Advanced technologies, such as High Pressure Common Rail (HPCR) injection system, air-to-air aftercooler and efficient turbo-charger enables the engine to be U.S. EPA Tier 2 emission certified. High torque at low speed, impressive acceleration, and low fuel consumption ensure maximum productivity.

Mode Selection System with Variable HorsePower Control

The system allows selection of the appropriate engine output mode <Power mode > or <Economy mode>, according to the working condition. The mode is easily selected with the switch in the operator's cab. When the key switch is turned on, Economy mode is selected automatically. Power mode can be selected by using the switch when needed.

Variable HorsePower Control

Both in Power and Economy modes, the Variable HorsePower Control system detects whether the machine is loaded or unloaded and selects the optimum horsepower setting mode, providing both high production and low fuel consumption.

Power mode: Makes best use of the horsepower to attain optimal production. This mode is suitable for operations including uphill travel loaded where throughput is the top priority.

Economy mode: Sets the maximum horsepower at a lower level to reduce fuel consumption. The machine maintains sufficient power for normal operation in this mode.



F7-R2 (RH/RL) Fully Automatic Transmission

The transmission is configured with 7 forward and 2 reverse gears. Fully automatic control is applied to all forward gears and an optimum gear is automatically selected according to the travel speed and engine speed. The shifting point is automatically selected depending on the acceleration of the machine to reduce excessive fuel consumption.



Two-speed Selective Reverse Gears (RH/RL)

In order to meet various operating conditions, two reverse gears are provided. The switch on the panel allows the operator to usually select the appropriate gear for the application, RH or RL depending on the job site conditions. Furthermore, the reverse gear is equipped with a lockup clutch, just like forward gears, allowing the operator to reverse the machine without concern of overheating.

RH: Suitable for normal operation. Thanks to the lockup clutch, the machine can be reversed at higher speed.

RL: Suitable for operation where steep grades are existing.

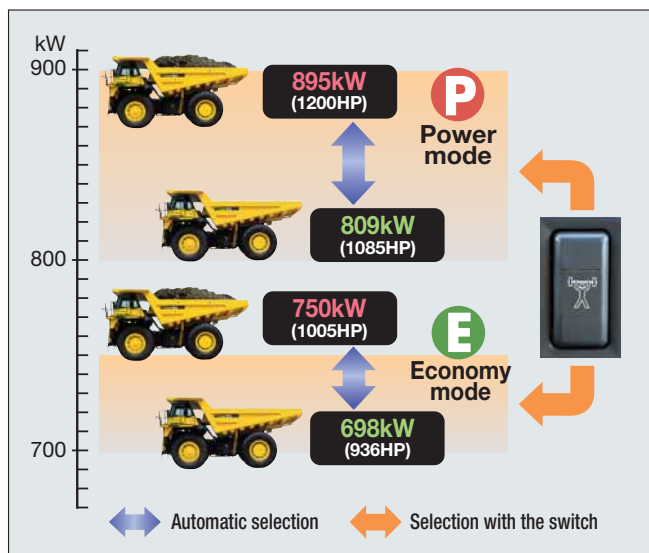

4-wheel Oil-cooled Multiple Disc Retarder

The machine is equipped with 4-wheel retarder that applies retarding force on all four wheels. With this retarder, the retarding force is shared between four wheels. This reduces the possibility of tire-lock and enables effective use of retarder capacity, allowing stable downhill travel. The machine descends slopes smoothly and comfortably.

Retarder absorbing capacity

1092 kW 1464 HP (Continuous descent)

Brake surface area

Front total: **37467 cm²**

Rear total: **72414 cm²**

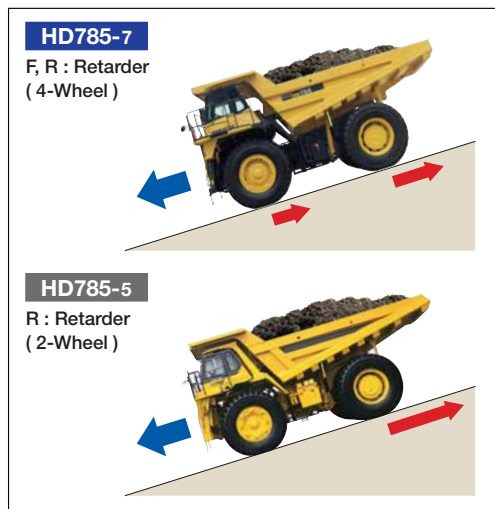

ARSC

ARSC allows the operator to simply set the downhill travel speed and descend grades at a constant speed. This allows the operator to concentrate on steering. The speed can be set at increments of 1 km/h per click (Within ± 5 km/h) to match the optimum speed for the slope. The retarder cooling oil temperature is constantly monitored and the descent speed is automatically reduced, if necessary.



Reducing Hydraulic Losses & Optimizing Transmission Control

Hydraulic circuits such as brake cooling, steering, hoist control, etc. are thoroughly reviewed and the transmission control is optimized to reduce the fuel consumption. As a result, the fuel consumption at medium and light load operations are improved.

Automatic Idling Setting System

This system facilitates quick engine warm-up and operator cab cooling/warming. When setting the system ON, engine idle speed is kept at 945 min^{-1} , but is lowered to 750 min^{-1} when the coolant temperature rises to 50°C . Speed automatically returns to 945 min^{-1} when the coolant temperature drops to 30°C .



Small Turning Radius

The MacPherson strut type front suspension has a special A-frame between each wheel and the main frame. The wider spaces created between the front wheels and the main frame increase the steering angle of the wheels. The larger this steering angle, the smaller the turning radius of the truck.

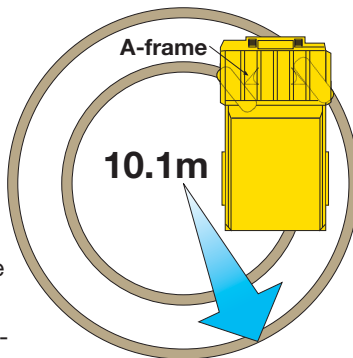

Turning radius varies depending on ground conditions and/or vehicle speed.

Long Wheelbase and Wide Tread

With an extra-long wheelbase, a wide tread and an exceptionally low center of gravity, the HD785-7 hauls the load at higher speed for greater productivity, and delivers superior driving comfort over rough terrain.



OPERATOR ENVIRONMENT

Spacious Cab with Excellent Visibility

Wide glass areas on front, side and back, plus plenty of space in the richly upholstered interior, provide a quiet, comfortable environment which enables to see and control every aspect of operation. Front underview mirrors also contributes to improve visibility.



Ergonomically Designed Cab

The ergonomically designed operator's compartment makes it very easy and comfortable for the operator to use all the controls. The result is more confident operation and greater productivity.



Easy-to-see Instrument Panel

The instrument panel makes it easy to monitor important machine conditions. In addition, a caution lamp warns the operator of any malfunctions that may occur. Malfunctions are recorded in the monitor and service codes, appear on the instrument panel. This makes the machine user friendly and easy to service.

Ideal Driving Position Settings

The 5-way adjustable operator seat and the tilt-telescopic steering column provide an optimum driving posture, for increased driving comfort and more control over machine operation. The suspension seat dampens vibrations transmitted from the machine and reduces operator fatigue as well as holding the operator securely to assure confident operation. 78 mm width seat belt is provided as standard equipment.

Radio with AUX Terminal (Optional)

To connect MP3 player etc., AUX terminal is prepared in the cab.



Synchronous Control of Engine and Transmission

At the time of gear shifting, the engine speed is controlled to coincide with transmission rotation speed to reduce shifting shocks. The synchronous control also contributes to improve durability of power train since it reduces torque fluctuation.

Komatsu Advanced Transmission with Optimum. Modulation Control System (K-ATOMiCS)

The electronically controlled all clutch modulation system Komatsu Advanced Transmission with Optimum. Modulation Control System (K-ATOMiCS) that optimizes the clutch engagement oil pressure at every gear is further improved so that the oil pressure at lockup clutch engagement is optimized to realize smooth shifting without torque off.

Skip shift function: Automatically selects the gear according to the slope grade when driving uphill without shifting down to the lower gear one by one. It reduces the number of down-shifts, makes the driving smoother, improves the operator's comfort and reduces spilling of material.

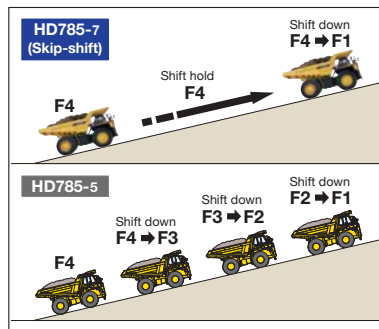

The MacPherson Strut Type Front Suspension

The MacPherson type independent suspensions are installed to the front wheels. The linkage arrangement with less friction allows the front wheel to follow the undulation of road surface smoothly, realizing excellent riding comfort.

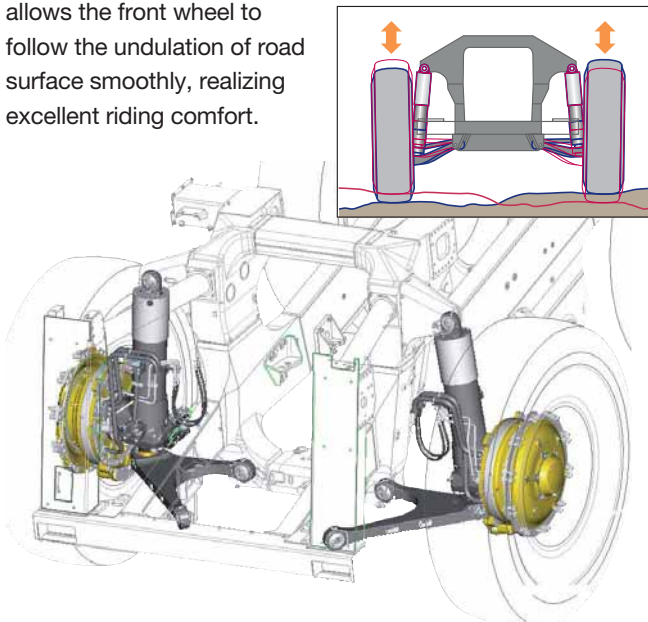

Three-mode Automatic Hydropneumatic Suspension (Optional)

Suspension mode is automatically switched to one of three stages (Soft, medium and hard) according to load and operating conditions, for a more comfortable and stable ride.

Viscous Cab Mounts

Large capacity viscous cab mounts with excellent damping performance are used to mount the cab. They reduce cab vibration significantly and provide comfortable cab space with superb quietness and less vibrations.

Noise level at operator's ear:
75 dB(A)

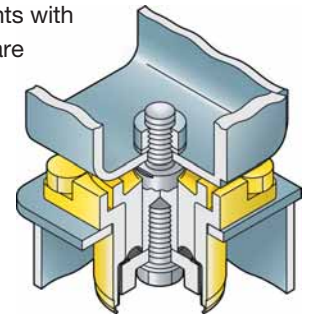

Electronic Hoist Control System

The control lever is short in travel and can be operated with a light effort. "Kick-out function" provided for the lever facilitates the hoist operation, eliminating a need to hold the lever in "Raise" position. Furthermore, body seating shock is significantly reduced because a sensor detects the body just before seating on the frame and reduces the lowering speed.



SAFETY

Built-in ROPS/ FOPS Cab

These structures conform to ISO 3471 ROPS standard, and ISO 3449 FOPS standard.



LED Rear Combination Lamp

LED lamps are used for the rear combination lamp. The LED lamp features long service life and excellent visibility while it is an energy-saving lamp.



Under Mirror

The new round under-mirror provides a wider field of vision.



Spiked Slip-resistant Plate

Steps and walkways are made with spiked slip-resistant plates to improve safety when you get on or off the machine or move around on the machine.



Parking Brakes on 4-wheels

The machine is equipped with spring applied parking brakes on 4-wheels. Wet multiple disc brakes built in both front and rear axles apply braking force to all four wheels. These brakes are highly reliable and require no periodic maintenance.



Front brake

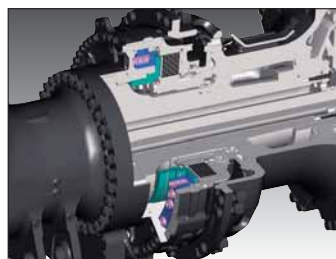

Rear brake

Large Screen, Color Rearview Camera & Monitor (Optional)

Rearview camera and 7-inch color LCD monitor are available to improve rear visibility. This device serves to improve safety and workability of the machine.



Pedal-operated Secondary Brake

If there should be a failure on the primary brake circuit, both front and rear parking brakes are activated as a pedal operated secondary brake.



Antilock Brake System (ABS) (Optional)

Using its outstanding electronics technology, Komatsu is the first in the industry to introduce ABS on construction machinery. This system prevents the tires from locking, thus minimizes skidding under slippery conditions while applying the service brake.

Secondary Steering and Secondary Brake

Secondary steering and secondary brake are standard features.

Steering: ISO 5010, SAE J1511 Brake: ISO 3450

Komatsu Traction Control System (KTCS) (Optional)

KTCS automatically prevents the rear tire on either side from slipping on soft ground for optimal traction.

RELIABILITY

Komatsu Components

Komatsu manufactures the engine, torque converter, transmission, hydraulic units, and electronic components on this dump truck. All these components are manufactured with an integrated production system under strict quality control guidelines.

High-rigidity Frame

Front deck supports are integrated with the frame. The frame rigidity is increased drastically. As a result, flexural rigidity and torsional rigidity that are indicators of drivability and riding quality are significantly improved.

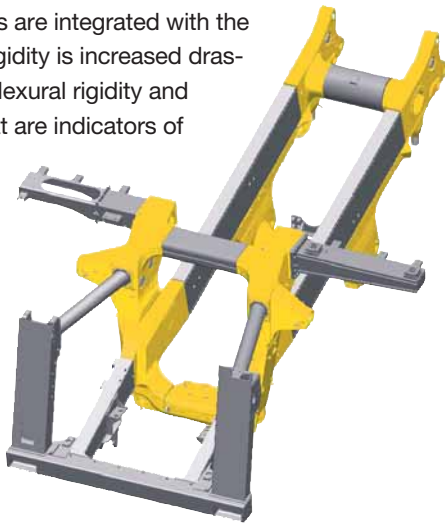

Reliable Hydraulic System

A large capacity oil cooler is installed in each hydraulic circuit, improving the reliability of the hydraulic units during sudden temperature rises. Further, in addition to the main filter, $\beta_{10} = 3$ (min) line filter is located at the entrance to the transmission control valve.

Flat Face-to-face O-ring Seals

Flat face-to-face O-ring seals are used to securely seal all hydraulic hose connections and to prevent oil leakage.

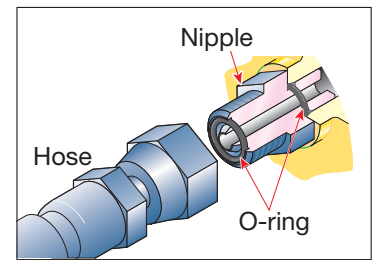

Sealed Connectors

Main electric harnesses and controller connectors are equipped with sealed connectors providing high reliability, water resistance and dust resistance.



For Better Operational Management and Safety

In actual Operational Management activities, the first step to effective use of the HD785-7 is to record each payload. For this purpose, Komatsu has made the "Payload meter" available.

Based on the premise that "Payload meter" can record the payload data, Komatsu intends to apply "Loading Policy" that is intended to be used as guidelines for consistent and better "Operational Management"

Loading Policy

Each dump truck has its own "target payload". Operating a dump truck with an extraordinary payload causes the following adverse effects.

- Operating an underloaded truck cannot fully utilize the vehicle performance and increases the number of round trips required to haul the same quantity of materials, resulting in increased cost-per-ton.
- Operating an overloaded truck causes early wear on brake discs, tires, etc., and shortens the life of components such as drive system etc. resulting in increased maintenance and repair costs.

Our proposal "Loading Policy" relies on an assumption that each HD785-7 is equipped with a "Payload Meter" and each payload is positively recorded. Target payload is defined as rated Gross Vehicle Weight (GVW) minus Empty Vehicle Weight (EVW) with linear and/or attachments.

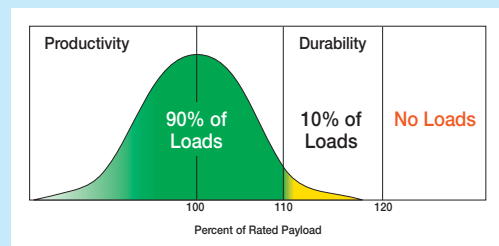

- 1) The monthly average payload must not exceed the target payload of the truck.
- 2) 90% of all loads must be below 110% of the target payload of the truck.
- 3) 10% of all loads may be between 110% and 120% of the target payload of the truck.
- 4) Any single load must not exceed 120% of the target payload of the truck.

Observance of the "Loading Policy" results in improvement of productivity by full utilization of the performance of HD785-7, reduction of running cost, and extension of the life of brakes, tires, and other components.

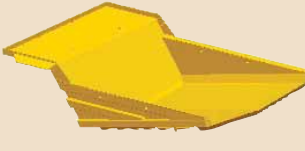

Selection of Body

Several different types of bodies are selectively available for the HD785-7 and optional equipment for the bodies are also prepared for use in various conditions.

Material \ Loading machine	Shovel, Backhoe (Severity to body: Light)	Wheel loader (Severity to body: Heavy)
Construction Overburden (Severity to body: Light)	 <p>Light weight body (Optional)</p> <p>Recommended use of this body includes relatively light-duty works such as construction and hauling of overburden, coal, etc. Material thickness: t16/12/8 (Bottom/front/side)</p>	
Quarry (Severity to body: Medium)	 <p>General purpose body (Standard)</p> <p>This body is designed for various uses as standard. Major portions of this body are made of abrasion-resistant steel plates to assure high durability. Material thickness: t19/12/9 (Bottom/front/side)</p>	
Ore (Severity to body: Heavy)	 <p>Rock body (Optional)</p> <p>This rock body is made by attaching liner plates to the general purpose body. Recommended use of this body is relatively heavy-duty works such as hauling of ores, etc. There are various kinds of thickness and form of liner. Please consult with Komatsu distributor for details.</p>	

*Description of "Light", "Medium" and "Heavy" are rule-of-thumb. Please consult with Komatsu distributor when you select the body.

ECOLOGY

Lead-free Radiator

Several different types of bodies are selectively available for the HD785-7 and optional equipment for the bodies are also prepared for use in various conditions.

Brake Cooling Oil Capture Tank

To protect the environment, a tank is installed to capture brake cooling oil in the event of brake floating seal leakage.



EASY MAINTENANCE

Advanced Monitoring System

The Komatsu advanced monitoring system identifies maintenance items, indicates oil and filter replacement times left and displays abnormality codes. This monitor system helps to reduce diagnostic times and maximize machine production time.



Wet Multiple-disc Brakes and Fully Hydraulic Controlled Braking Systems

Realize lower maintenance costs and higher reliability. Wet disc brakes are fully sealed to keep contaminants out, reducing wear and maintenance. The brakes require no adjustments for reducing wear, meaning even lower maintenance. The parking brake is also an adjustment-free, wet multiple-disc system for high reliability and long life. Added reliability is designed into the braking system by the use of three independent hydraulic circuits providing hydraulic backup should one of the circuits fail. Fully hydraulic braking systems eliminate the air system so air bleeding is not required, and water condensation that can lead to contamination, corrosion and freezing is eliminated.

Extended Oil Change Intervals

In order to minimize operating costs, oil change intervals are extended:

Engine oil: 500 hours Hydraulic oil: 4000 hours

Centralized Arrangement of Filters

The filters are centralized so that they can be serviced easily.



Disc Wheels (Flange Type Rims)

Disc wheels (Flange type rims) provide easy removal/installation of the tires.



Electric Circuit Breaker

Circuit breakers are adopted in important electric circuits that should be restored in a short time when a malfunction occurs in the electrical system.



Centralized Greasing Points

Greasing points are centralized at three locations. It enables to approach from ground level.



KOMTRAX Plus

KOMTRAX Plus controller monitors the health conditions of major components and enables remote analysis of the machine condition and its operation. This process is supported by the Komatsu distributors, factory and design team.

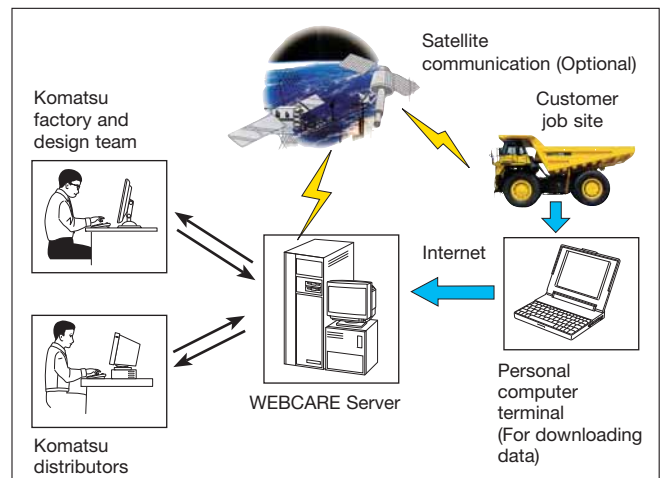

Payload Meter (PLM) (Optional)

PLM allows the production volume and the working conditions of the dump truck to be analyzed and controlled directly via a personal computer. The loadage is also indicated with the outside lamps. The system can store data of 2900 max. working cycles.



SPECIFICATIONS**ENGINE**

Model	Komatsu SAA12V140E-3
Type	Water-cooled, 4-cycle
Aspiration	Turbo-charged, after-cooled
Number of cylinders	12
Bore x Stroke	140 mm x 165 mm
Piston displacement	30.48 L
Horsepower	
SAE J1995	Gross 895 kW 1200 HP
ISO 9249 / SAE J1349	Net 879 kW 1178 HP
Rated rpm	1900 min ⁻¹
Fan drive type	Mechanical
Maximum torque	5080 N m 518 kgm
Fuel system	Direct injection
Governor	Electronic control
Lubrication system	
Method	Gear pump, force-lubrication
Filter	Full-flow type
Air cleaner	Dry type with double elements and precleaners, with dust indicator

U.S. EPA Tire 2 emission certified.

**TRANSMISSION**

Torque converter	3-elements, 1-stage, 2-phase
Transmission	Full-automatic, planetary-gear type
Number of gear	7 forward and 2 reverse (RH, RL)
Lockup clutch	Wet, multiple-disk clutch
Forward	Torque converter drive in 1st gear, direct drive in 1st lockup and all higher gears
Reverse	Torque converter drive, direct drive (Lockup)
Shift control	Electronic shift control with automatic clutch modulation in all gears
Maximum travel speed	65 km/h

**AXLES**

Rear axles	Full-floating
Final drive type	Planetary gear
Ratios:	
Differential	3.357
Planetary	6.333

**SUSPENSION SYSTEM**

Independent, hydropneumatic suspension cylinder with fixed throttle to dampen vibration.	
Effective cylinder stroke:	
Front suspension	320 mm max.
Rear suspension	127 mm max.
Rear axle oscillation	6.5° max.

**STEERING SYSTEM**

Type	Fully hydraulic power steering with two double-acting cylinders
Secondary steering	Meets ISO 5010, SAE J1511
Minimum turning radius	10.1 m
Maximum steering angle	41°

**CAB**

Standard	FOPS (ISO 3449 level 2) ROPS (ISO 3471)
----------	--

**MAIN FRAME**

Type	Box-sectioned structure, integral front bumper
------	--

**BRAKES**

Brakes meet ISO 3450 standard.	
Service brakes:	
Front	Fully hydraulic control, oil-cooled multiple-disc type
Rear	Fully hydraulic control, oil-cooled multiple-disc type
Parking brake	Spring applied, multiple-disc type (Actuates on all wheels)
Retarder	Oil-cooled, multiple-disc front and rear brakes act as retarder.
Secondary brake	Pedal operation
When hydraulic pressure drops below the rated level, parking brake is automatically actuated.	
Brake surface	
Front	37467 cm ²
Rear	72414 cm ²

**BODY (GENERAL PURPOSE BODY)**

Capacity:	
Struck	40 m ³
Heaped (2:1, SAE)	60 m ³
Rated payload	91.7 metric tons
Material	400 Brinell hardness high tensile strength steel
Structure	V-shape body with V-bottom
Material thickness:	
Bottom	19 mm
Front	12 mm
Sides	9 mm
Target area	
(Inside length x width)	7070 mm x 5150 mm
Dumping angle	48°
Height fully raised	10080 mm
Bond prevention	Heating by exhaust gas

**HYDRAULIC SYSTEM**

Hoist cylinder	Twin, 2-stage telescopic type
Relief pressure	20.6 MPa 210 kg/cm ²
Hoist time	
Raise	13 s
Lower	14 s

**WEIGHT (APPROXIMATE)**

Rated Empty Vehicle Weight (EVW)	72000 kg
Excludes optional equipments and operator.	
Rated Gross Vehicle Weight (GVW)	163780 kg
Includes optional equipments, operator (80 kg) and payload.	
Distribution:	
Empty: Front axle	47%
Rear axle	53%
Loaded: Front axle	31.4%
Rear axle	68.6%

**TIRES**

Standard tire	27.00 R49
---------------	-----------

**SERVICE REFILL CAPACITIES**

Fuel tank	1308 L
Engine oil	129 L
Torque converter, transmission and retarder cooling	205 L
Differential	137 L
Final drives (Total)	128 L
Hydraulic system	175 L
Brake control	36 L
Suspensions (Total)	93 L



DIMENSIONS

Unit: mm

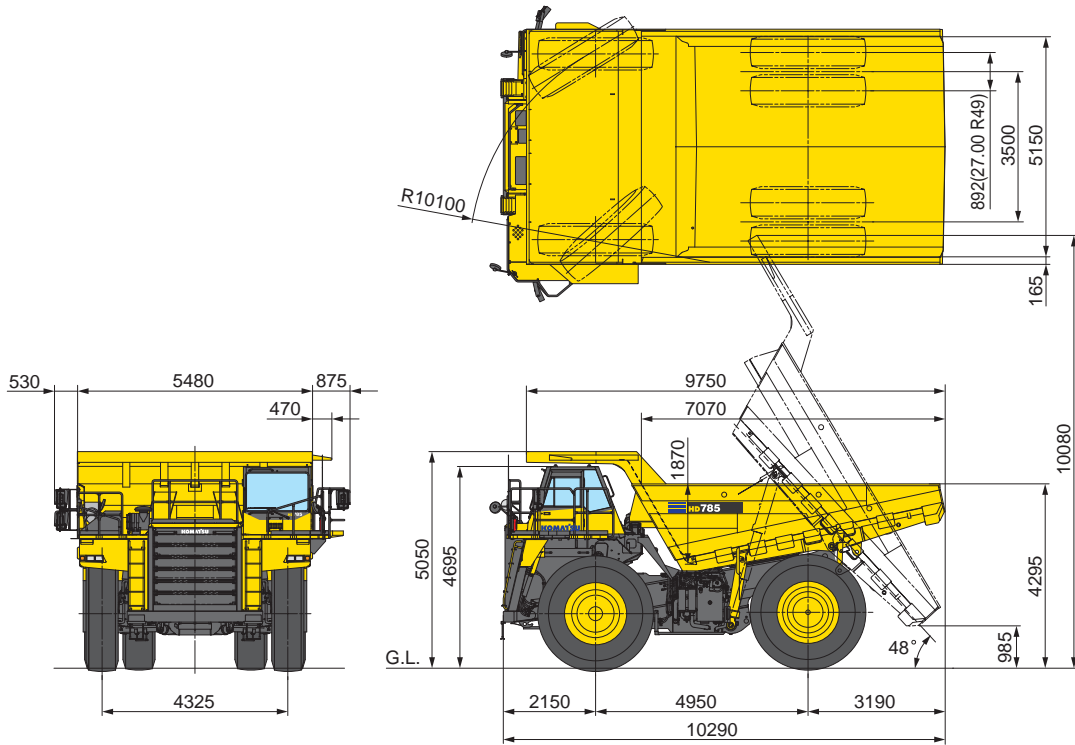

TRAVEL PERFORMANCE

Read from gross weight down to a line for total resistance in percentage. From this weight-resistance intersection, read horizontally to the curve with the highest obtainable speed range, then down to maximum speed. Usable rimpull depends upon traction available and weight on drive wheels.

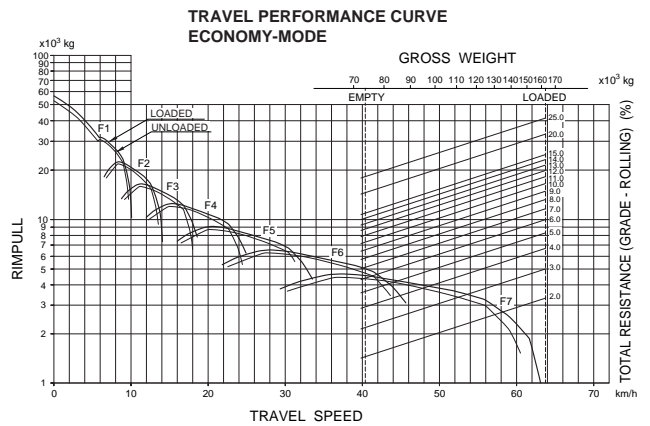
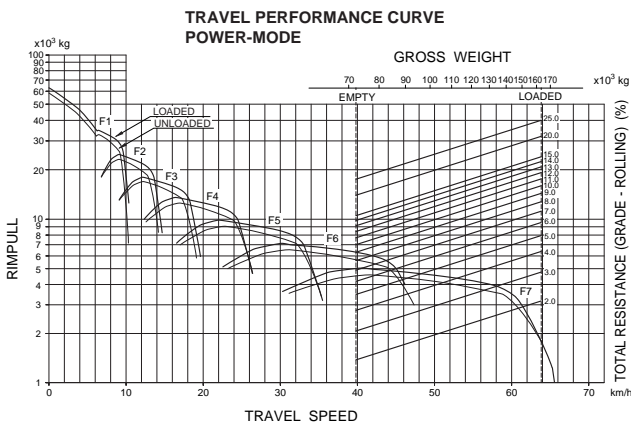

BRAKE PERFORMANCE

These curves are provided to establish the maximum speed and gear position for safer downhill travel with a given distance. Read from gross weight down to a line for total resistance in percentage. From this weight resistance intersection, read horizontally to the curve with the highest obtainable speed range, then down to maximum downhill travel speed the brakes can safely handle without exceeding cooling capacity.

Grade distance: Continuous Descent

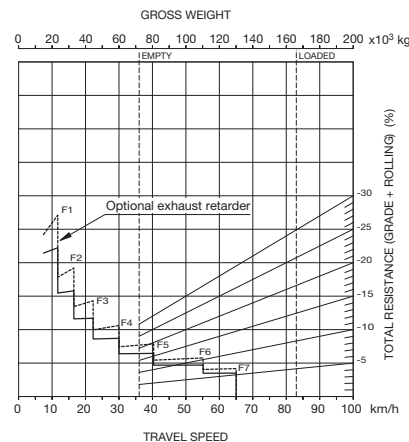

Grade distance: 450 m

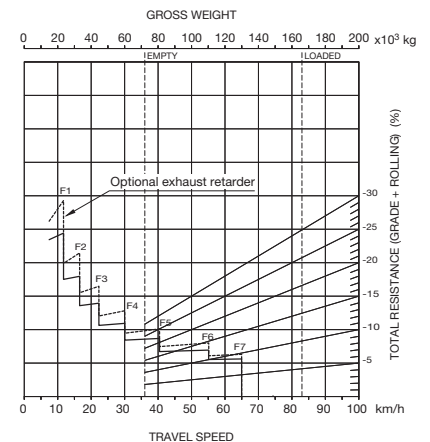

**STANDARD EQUIPMENT****ENGINE:**

- Alternator, 90 A/24 V
- Automatic Idling Setting System
- Batteries, 4 x 12 V/170 Ah
- Engine, Komatsu SAA12V140E-3
- Mode selection system with Variable HorsePower Control
- Starting motors, 2 x 7.5 kW

CAB:

- Ashtray
- Built-in ROPS and FOPS, sound suppression type (ISO 3471/ISO 3449)
- Cigarette lighter
- Cup holder
- Electronic hoist control system
- Electronic maintenance display/monitoring system
- Laminated glass, front
- Operator seat, reclining, suspension type with 2-point retractable 78 mm width seat belt
- Power window (LH)
- Space for lunch box
- Steering wheel, tilt and telescopic
- Sun visor

- Trainer seat with retractable seat belt
- Two doors, left and right
- Windshield washer and wiper (With intermittent feature)

LIGHTING SYSTEM:

- Back-up lamp
- Hazard lamps
- Headlamps
- LED rear combination lamps
- Turn signal

GUARD AND COVERS:

- Canopy side guard, cab side
- Canopy spill guard
- Drive shaft guards (Front and rear)
- Exhaust thermal guard
- Fire protective covers

SAFETY EQUIPMENT:

- 4-wheel oil-cooled multiple disc retarder
- Alarm, backup
- ARSC
- Coolant temperature alarm and lamp
- Guard rails for platform
- Horn, electric

- Ladders, left and right hand sides
- Neutral coast inhibitor
- Overrun warning system
- Rearview mirrors and under view mirrors
- Secondary brake
- Secondary steering, automatic, electrical

OTHER:

- Centralized greasing
- Disc wheels (Flange type rims)
- Electric circuit breaker, 24 V
- KOMTRAX Plus
- Mud guards

BODY:

- Body exhaust heating

TIRES:

- 27.00 R49

**OPTIONAL EQUIPMENT****CAB:**

- 3-point retractable seat belt (Operator seat)
- Air conditioner
- AM/FM radio with AUX terminal
- Operator seat, air suspension type
- Power window (RH)
- Sunvisor, additional

BODY:

- Body liners
- Light weight body
- Muffler (Without body heating)
- Platform guard, rearward, right hand side
- Rock body

LIGHTING SYSTEM:

- Buck-up lamp additional
- Fog lamps
- HID head lamp (High/low)
- HID side work lamps
- LED head lamp
- LED side work lamps
- Side work lamps, rearward, left and right sides

SAFETY:

- ABS
- Battery disconnect switch
- Color rear view camera and monitor
- Diagonal ladder
- Engine shutdown switch, ground level
- Exhaust retarder
- Fuel tank step
- KTCS
- Power ladder
- Speed limiter
- Speed limiter (Over load)
- Tire stopper blocks

ARRANGEMENT:

- Batteries for cold area arrangement
- Cold area arrangement
- Sandy and dusty area arrangement

OTHER:

- Auto-greasing system
- Auto-greasing system with refill from ground level
- Engine coolant heater
- Engine oil pan heater

- Engine pre-lubrication
- Engine side cover
- Engine underguard
- Fast coolant fill
- Fast fuel fill
- Fast fuel fill from LH
- Fast oil fill
- Fire extinguisher
- KOMTRAX Plus (With satellite communication kit)
- Payload Meter
- Smart change rim
- Spare parts for first service
- Three-mode automatic hydropneumatic suspension
- Tool kit
- Transmission underguard
- Vandalism protection

Standard equipment may vary for each country, and this specification sheet may contain attachments and optional equipment that are not available in your area. Please consult your Komatsu distributor for detailed information.

