

KOMATSU®

WA470-5

WA
470

HORSEPOWER

Gross: 204 kW 273 HP / 2000 min⁻¹

Net: 195 kW 261 HP / 2000 min⁻¹

OPERATING WEIGHT

22085 – 22315 kg

BUCKET CAPACITY

3.6 – 5.2 m³



Photos may include optional equipment.

WALK-AROUND





HIGH PRODUCTIVITY & LOW FUEL CONSUMPTION

- Powerful Engine
- Dual-mode Select System
- Transmission Mode Select System
- Maximum Dumping Clearance and Reach

INCREASED RELIABILITY

- Reliable Komatsu Components
- High-rigidity Frames
- Wet Multiple-disc Brakes and Fully Hydraulic Braking System

EASY MAINTENANCE

- Equipment Management Monitoring System
- Gull-wing Type Engine Side Doors Open Wide
- Reversible Cooling Fan (Optional) and Swing-out Cooler Elements

EXCELLENT OPERATOR ENVIRONMENT

- Pillar-less Large Cab
- Fingertip Work Equipment Control Lever
- Electrically Controlled Transmission Lever
- Automatic Transmission with Electronically Controlled Modulation Valve

SAFETY

- ROPS/FOPS Cab (ISO 3471/ISO 3449)
- Rear-hinged Full Open Cab Door

KOMTRAX

- KOMTRAX

WA470-5

HORSEPOWER	Gross: 204 kW 273 HP / 2000 min ⁻¹
	Net: 195 kW 261 HP / 2000 min ⁻¹
OPERATING WEIGHT	22085 – 22315 kg
BUCKET CAPACITY	3.6 – 5.2 m ³

HIGH PRODUCTIVITY & LOW FUEL CONSUMPTION



Powerful Engine

The electronically controlled fuel injection timing in the SAA6D125E-3 engine provides optimum combustion of fuel at both low and high speed/power applications. This system also provides fast throttle response to match the machine's powerful rim pull and fast hydraulic response.

195 kW 261 HP (Net)

The common rail type fuel injection system provides maximum power with minimum emissions. This engine is U.S. EPA Tier 2 and EU Stage 2 emissions certified.



Dual-mode Select System

This wheel loader offers two selectable operating modes—Normal and Power. The operator can adjust the machine's performance by flipping a switch.

- **Normal Mode:** This mode provides maximum fuel efficiency for most of general loading.
- **Power Mode:** This mode provides maximum power output for hard digging operation or hill climb.

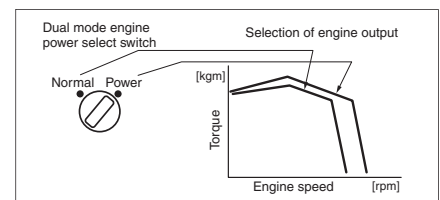

Low Fuel Consumption

The fuel consumption is reduced greatly because of the low-noise, high-torque engine and the large-capacity torque converter with maximum efficiency in the low-speed range.

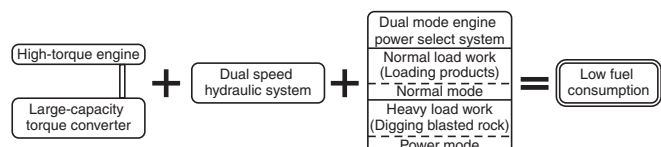

Transmission Mode Select System

This operator controlled system allows the operator to select manual shifting or three levels of automatic shifting (low, medium, and high).

- **Manual:** Transmission is fixed to gear speed selected with gear shift lever.
- **Auto. H:** This mode provides large rim pull and short cycle time since gear shifting is performed at relatively high engine speeds, suitable for load and carry operation on uphill.
- **Auto. M:** Gear is shifted at medium engine speeds between those of L and H modes.
- **Auto. L:** This mode provides smooth gear change and low fuel consumption since gear shifting is performed at relatively low engine speeds, suitable for general excavating and loading.



Transmission mode	Shift range		
	F2	F3	F4
H mode	Blue	Pink	Green
M mode	Blue	Pink	Green
L mode	Blue	Pink	Green

Maximum Dumping Clearance and Reach

The long lift arms provide high dumping clearances and maximum dumping reach. The operator can even level loads on the body of a dump truck easily and efficiently.

(4.2 m³ bucket with Bolt on Cutting Edge, 26.5-25 tires)



New Dual-speed Hydraulic System

Komatsu's dual-speed hydraulic system increases operational efficiency by matching the hydraulic demands to work conditions.

Oil from the switch pump is completely returned to the tank when digging and breaking out, therefore, hydraulic flow to the loader is reduced and pressure is increased. This reduces horsepower demand from the engine and makes the operation more efficient. Kick-down switch signal also controls the oil flow. This new technology is greater productivity at the lowest operating cost.

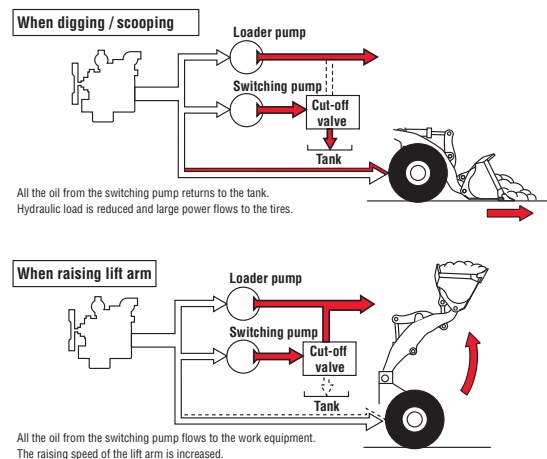

Long Wheelbase/Articulation Angle of 40°

The longest wheelbase in class and the widest tread provide improved machine stability in both longitudinal and lateral directions. Since the articulation angle is 40°, the operator can work efficiently even in the tightest job sites.

Tread	2300 mm
Wheelbase	3450 mm
Minimum turning radius (center of outside tire)	5900 mm

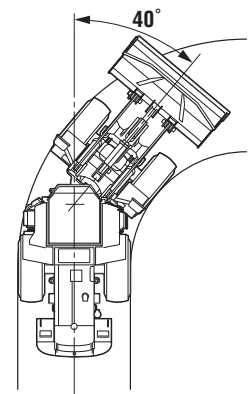

INCREASED RELIABILITY



Reliable Komatsu Components

Komatsu manufactures the engine, torque converter, transmission, hydraulic units, electric parts, and even each bolt on this wheel loader. Komatsu loaders are manufactured with an integrated production system under a strict quality control system.

High-rigidity Frames and Loader Linkage

The front and rear frames have high rigidity to bear twisting and bending loads applied repeatedly to the loader body. Both upper and lower center pivot bearings are tapered roller bearings having high durability. The structure is similar to those of large-sized loaders and the reinforced loader linkage also ensures high rigidity.

Komatsu Components

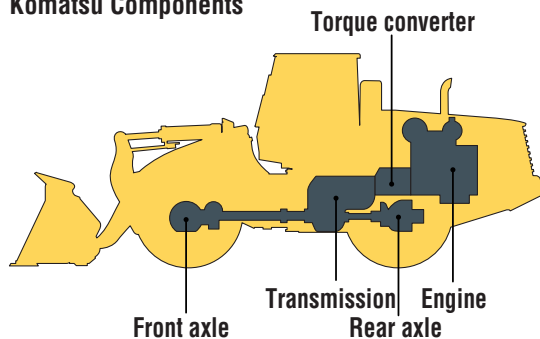

Cation Electrodeposition Primer Paint/ Powder Coating Final Paint

Cation electrodeposition paint is applied as a primer paint and powder coating is applied as topcoat to the exterior metal sheet parts. This process results in a beautiful rust-free machine, even in the most severe environments. Some external parts are made of plastic providing long life and high impact resistance.

Flat Face-to-face O-ring Seals

Flat face-to-face O-ring seals are used to securely seal all hydraulic hose connections and to prevent oil leakage. In addition, buffer rings are installed to the head side of the all-hydraulic cylinders to lower the load on the rod seals and maximize the reliability.

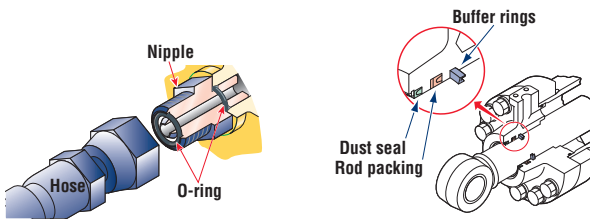

Sealed Connectors

Main harnesses and controller connectors are equipped with sealed connectors providing high reliability, water resistance and dust resistance.

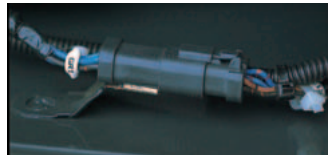

Halogen Head Lamps

Reliable halogen lamps are used for the head lamp. Since the bulbs of the head lamp and the working lamp are replaceable, the repair cost of these lamps is reduced.



Wet Multiple-disc Brakes and Fully Hydraulic Braking System

This means lower maintenance costs and higher reliability. Wet disc brakes are fully sealed. Contaminants are kept out, reducing wear and resulting maintenance. Brakes require no adjustments for wear, meaning even lower maintenance. The parking brake is also an adjustment-free, wet multiple-disc for high reliability and long life.

If the brake oil pressure drops, the warning lamp flashes and the warning buzzer sounds intermittently. If the brake pressure drops lower, the parking brake is applied providing a double safety system.

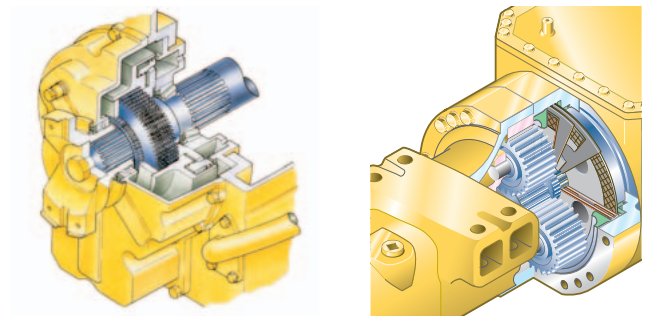

Bucket Side Guard (Optional)

In addition to the conventional side guard of plate type (for loading products), the bolt-on side guard made of cast steel can be installed optionally. Since it is so designed that the material can flow smoothly on it, it does not increase the digging resistance.



EASY MAINTENANCE



Equipment Management Monitoring System

Monitor is mounted in front of the operator allowing the operator to easily check gauges and warning lights. A specially designed two-spoke steering wheel allows the operator to easily see the instrument panel.

Maintenance Control and Troubleshooting Functions

- **Action code display function.** If the loader has any troubles, the monitor displays action details on the character display at the center bottom of the monitor.
- **Monitor function.** Controller monitors engine oil level, pressure, coolant temperature, air cleaner clogging etc. If controller finds abnormalities, all of these are displayed on LCD.
- **Replacement time notice function.** Monitor informs replacement time of oil and filters on LCD when it reaches replacement intervals.
- **Trouble data memory function.** Monitor stores abnormalities for effective troubleshooting.

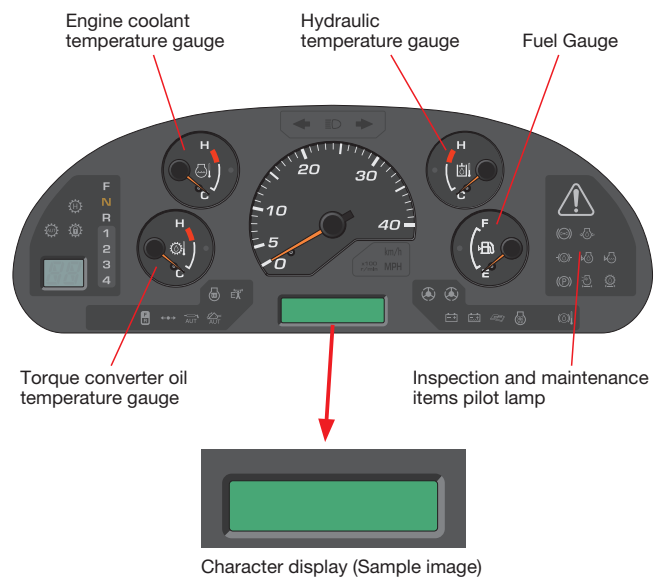

Gull-wing Type Engine Side Doors Open Wide

The operator can open and close each gull-wing type engine side door easily with the assistance of a gas spring to perform daily service checks from the ground.



Reversible Cooling Fan (Optional) and Swing-out Cooler Elements

If the machine is operating in adverse conditions, the operator can reverse the hydraulic cooling fan from inside the cab by turning on a switch on the control panel. The coolers can also swing out for easy cleaning.



Lengthened Maintenance Interval

Lengthened engine oil replacement interval:

250 H → 500 H

Lengthened drive shaft greasing interval:

1000 H → 4000 H

Battery Disconnect Switch (Optional)

The battery disconnect switch is located in the right battery box. This can be used to disconnect power when performing service work on the machine.

Easy-to-replace Air Conditioner Air-inlet Filter

The operator can replace the air conditioner air-inlet filter easily by opening the one-touch opening door on the right side of the cab.

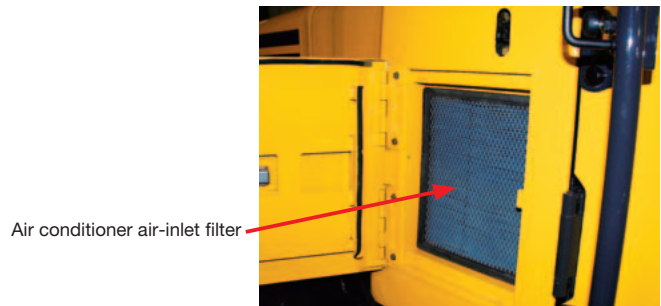

Easy-to-inspect Washer Tank and Radiator Sub Tank

Washer tank

Since the washer tank is installed under the left floor step, the operator can check the liquid level easily from the ground.



Radiator sub tank

With the right engine side door open, the operator can check the liquid level easily through the inspection window of the bulkhead from the ground.



Inspection window

EXCELLENT OPERATOR ENVIRONMENT



Pillar-less Large Cab

A wide pillar-less flat glass provides excellent front visibility. The wiper arm covers a large area to provide great visibility even on rainy days. The cab area is the largest in its class providing maximum space for the operator.



Low-noise Design

The large cab is mounted with Komatsu's unique ROPS/FOPS (ISO 3471/ISO 3449) viscous mounts. The low-noise engine, hydraulically driven fan, and hydraulic pumps are mounted with rubber cushions, and the cab sealing is improved to provide a quiet, low-vibration, dustproof with pressurizing, and comfortable operating environment.

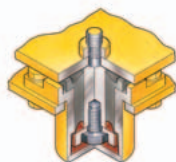

Telescopic/Tilt Steering Column

The operator can tilt and telescope the steering column to provide a comfortable working position.

- ① Tilt adjustment
- ② Telescopic adjustment



Electrically Controlled Transmission Lever

Easy shifting and directional changes with Komatsu two-lever electronic shifting. Change direction or shift gears with a touch of the fingers without removing the shifting hand from the steering wheel. Solid state electronics and conveniently located direction and gear shift controls make this possible. Automatic shifts in ranges two through four keep production high and manual shifting at a minimum.

Directional lever

Gearshift lever



Automatic Transmission with Electronically Controlled Modulation Valve

Automatic transmission with Electronically Controlled Modulation Valve automatically selects the proper gear speed based on travel speed, engine speed, and other travel conditions. The Electronically Controlled Modulation Valve system engages the clutch smoothly to prevent lags and shocks when shifting. This system provides efficient machine operation and a comfortable ride.

• Kick-down switch

Consider this valuable feature for added productivity. With the touch of a finger, the kick-down switch automatically downshifts from second to first when beginning the digging cycle. It automatically upshifts from first to second when the direction control lever is placed in reverse. This results in increased rim pull for better bucket penetration and reduced cycle times for higher productivity.

• Hold switch

Auto shift is selected and if the operator turns on this switch when the lever is at the 3rd or 4th gear speed position, the transmission is fixed to that gear speed.

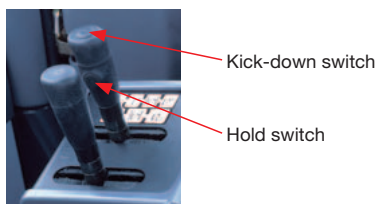
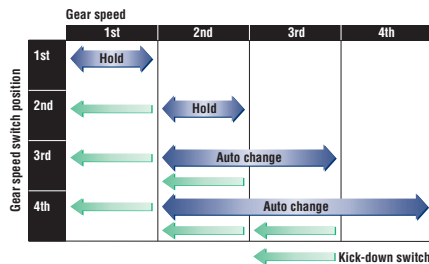

Variable Transmission Cut-off

The operator can adjust the transmission cut-off connected to the left brake pedal with the switch near the operator's seat to set the brake/cut-off point for easier operation and higher operating performance in variable operating conditions.

- High cut-off pressure for piling up operations.
- Low cut-off pressure for truck-loading operations.

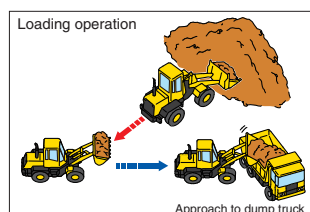
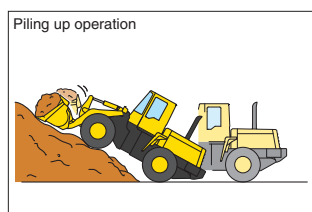

Fingertip Work Equipment Control Lever

The Proportional Pressure Control (PPC) levers are used for the work equipment. The operator can easily operate the work equipment with fingertip control, reducing operator fatigue and increasing controllability. The operator can adjust the height of the wrist rest to obtain the best operating position.

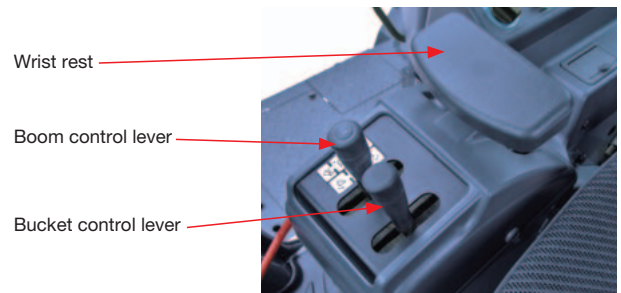

Sunshade

The sunshade is added to the top of the rear glass.



Door Sash with Assistant

The door sash with an assistant which can be opened and closed with one hand is employed.

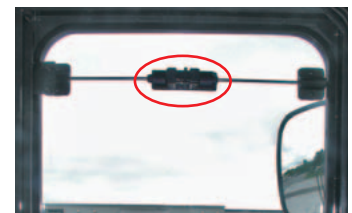

Air Conditioner

Since air is blown high in the cab, the cooling efficiency is increased further.

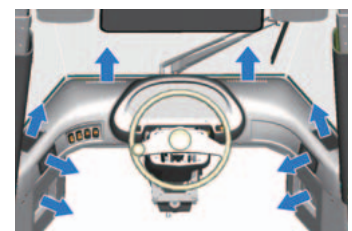

Sun Visor



ROPS/FOPS Cab

The ROPS/FOPS Cab is standard for operator's safety. A wide pillar-less flat glass provides excellent front visibility, and a heated rear window provides excellent rear visibility in cold and freezing weather conditions.

ROPS (ISO 3471) : Roll-over Protective Structure

FOPS (ISO 3449) : Falling Objects Protective Structure



Rear-hinged Full Open Cab Door

The cab door hinges are installed to the rear side of the cab providing a large opening angle for the operator to enter and exit. The steps are designed like a staircase, so that the operator can get on and off the cab easily.



Laminated Glass

The front glass is changed from tempered glass to laminated glass to improve safety when it is broken.

Large Safety Lock Lever

To prevent the work equipment from dropping if work equipment control lever should be touched by accident when the operator gets on or off the machine, the size of the lock lever used to lock the work control levers has been increased. Furthermore, the safety lock lever is so designed for safety that the operator cannot get on and off the cab from the right side while the work equipment lever is unlocked.

Work equipment safety lock lever

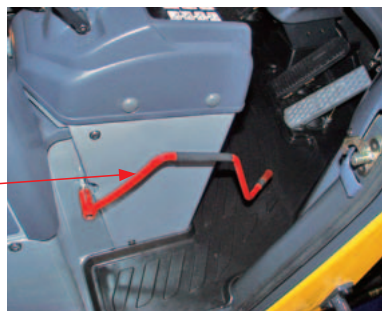

Left or Right Side Cab Entry

The operator can get on and off the machine from either side of the vehicle. This design is convenient when getting on and off in a narrow jobsite or on uneven ground.

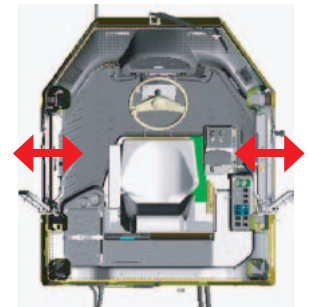

Safety Features

Secondary steering

If the steering pump is disabled, a secondary steering pump provides hydraulic flow.

Two independent lines brake system

Added reliability is designed into the braking system by the use of two independent hydraulic circuits, providing hydraulic backup should one of the circuits fail.

KOMTRAX

Assists Customer's Equipment Management and Contributes to Fuel Cost Cutting

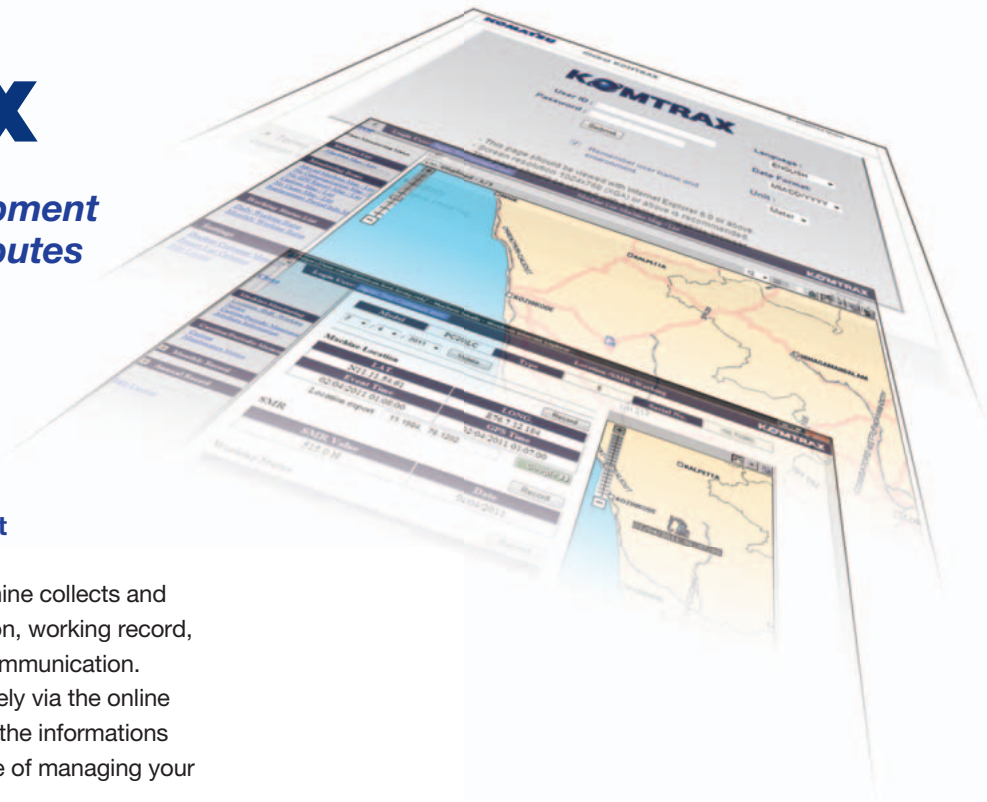

Equipment Management Support

KOMTRAX terminal installed on your machine collects and sends information such as machine location, working record, machine conditions, etc. using wireless communication. You can review the KOMTRAX data remotely via the online application. KOMTRAX not only gives you the informations on your machine, but also the convenience of managing your fleet on the Web.

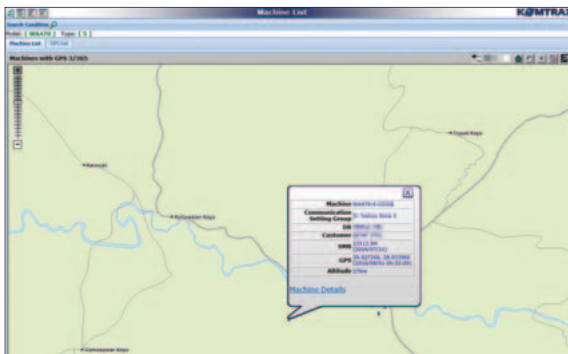

Location



Operation map

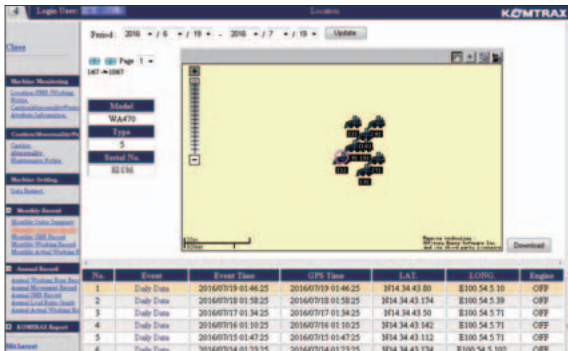

Movement generated position



Monthly status summary



DIMENSIONS

Measured with 26.5-25-20PR (L-3) tires

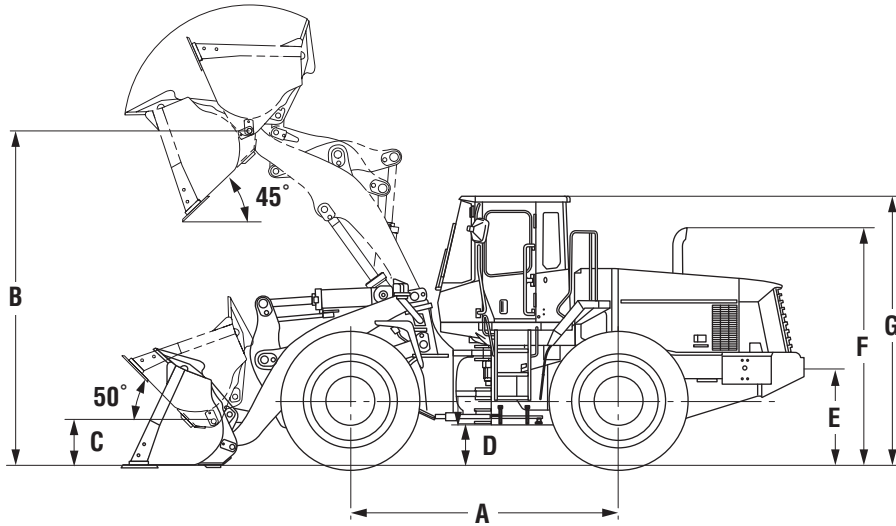

	Standard Boom	High Lift Boom
Tread	2300 mm	
Width over tires	3010 mm	
A Wheelbase	3450 mm	
B Hinge pin height, max. height	4360 mm	4870 mm
C Hinge pin height, carry position	585 mm	760 mm
D Ground clearance	525 mm	
E Hitch height	1240 mm	
F Overall height, top of the stack	3080 mm	
G Overall height, ROPS cab	3460 mm	

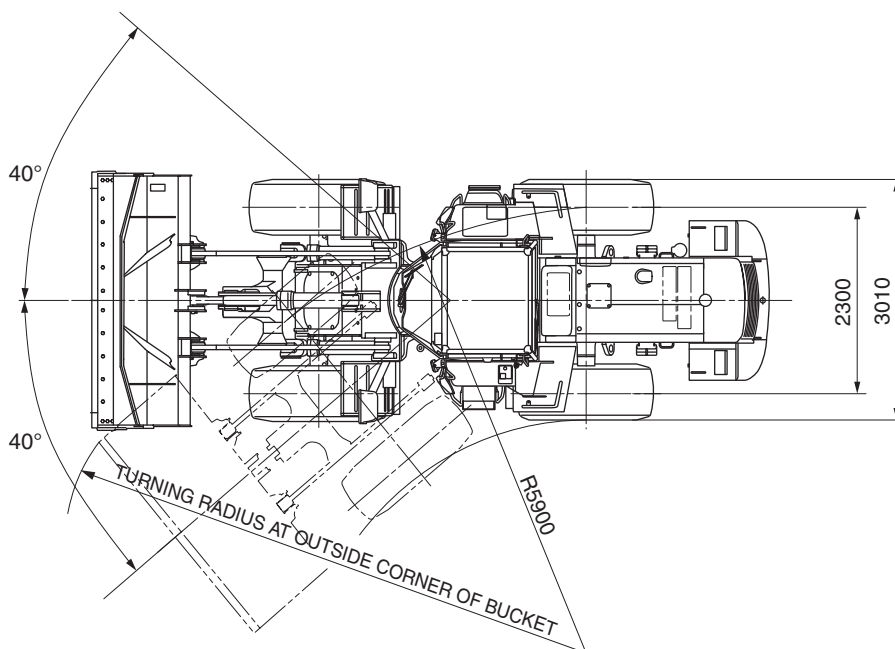



DIMENSIONS

Measured with 26.5-25-20PR (L-3) tires

Standard Boom	Stockpile Bucket			Excavating Bucket			Rock Bucket (Spade nose)	Loose Material Bucket			Light Material Bucket	
	B.O.C.	Teeth and Segments	Teeth	B.O.C.	Teeth and Segments	Teeth	Teeth	B.O.C.	Teeth and Segments	Teeth	B.O.C.	
Bucket capacity:	heaped	4.2 m ³	4.2 m ³	3.9 m ³	3.8 m ³	3.8 m ³	3.6 m ³	3.6 m ³	4.6 m ³	4.6 m ³	4.3 m ³	5.2 m ³
	struck	3.5 m ³	3.5 m ³	3.3 m ³	3.2 m ³	3.2 m ³	3.1 m ³	3.1 m ³	3.9 m ³	3.9 m ³	3.7 m ³	4.5 m ³
Bucket width		3170 mm	3190 mm	3190 mm	3170 mm	3190 mm	3190 mm	3170 mm	3170 mm	3190 mm	3190 mm	3170 mm
Bucket weight		2005 kg	2055 kg	1930 kg	2150 kg	2200 kg	2070 kg	2165 kg	2200 kg	2250 kg	2125 kg	2185 kg
Dumping clearance, max. height and 45° dump angle*		3185 mm	3060 mm	3060 mm	3235 mm	3110 mm	3110 mm	2975 mm	3055 mm	2930 mm	2930 mm	3035 mm
Reach at max. height and 45° dump angle*		1235 mm	1335 mm	1335 mm	1185 mm	1285 mm	1285 mm	1435 mm	1365 mm	1465 mm	1465 mm	1385 mm
Reach at 2130 mm clearance and 45° dump angle		1910 mm	1950 mm	1950 mm	1880 mm	1925 mm	1925 mm	2010 mm	1980 mm	2020 mm	2020 mm	1990 mm
Reach with arm horizontal and bucket level		2750 mm	2905 mm	2905 mm	2680 mm	2835 mm	2835 mm	3035 mm	2935 mm	3090 mm	3090 mm	2960 mm
Operating height (fully raised)		5960 mm	5960 mm	5960 mm	5875 mm	5875 mm	5875 mm	5875 mm	5960 mm	5960 mm	5960 mm	6185 mm
Overall length		8765 mm	8920 mm	8920 mm	8695 mm	8850 mm	8850 mm	9050 mm	8950 mm	9105 mm	9105 mm	8975 mm
Loader clearance circle (bucket at carry, outside corner of bucket)		13960 mm	14080 mm	14080 mm	13930 mm	14040 mm	14040 mm	13970 mm	14060 mm	14180 mm	14180 mm	14080 mm
Digging depth:	0°	80 mm	100 mm	100 mm	80 mm	100 mm	100 mm	85 mm	60 mm	80 mm	80 mm	60 mm
	10°	315 mm	360 mm	360 mm	305 mm	350 mm	350 mm	370 mm	345 mm	390 mm	390 mm	350 mm
Static tipping load:	straight	17215 kg	17170 kg	17295 kg	17005 kg	16955 kg	17085 kg	16990 kg	17045 kg	17000 kg	17125 kg	16970 kg
	40° full turn	14975 kg	14930 kg	15055 kg	14770 kg	14720 kg	14850 kg	14755 kg	14810 kg	14765 kg	14890 kg	14735 kg
Breakout force		192 kN	207 kN	207 kN	203 kN	209 kN	220 kN	190 kN	168 kN	183 kN	183 kN	165 kN
Operating weight		22165 kg	22210 kg	22085 kg	22205 kg	22315 kg	22185 kg	22280 kg	22225 kg	22270 kg	22145 kg	22300 kg

High Lift Boom	Stockpile Bucket	Excavating Bucket			
	B.O.C.	B.O.C.	Teeth and Segments	Teeth	
Bucket capacity:	heaped	3.6 m ³	3.8 m ³	3.8 m ³	3.6 m ³
	struck	3.1 m ³	3.2 m ³	3.2 m ³	3.1 m ³
Bucket width		3170 mm	3170 mm	3190 mm	3190 mm
Bucket weight		1915 kg	2254 kg	2190 kg	2075 kg
Dumping clearance, max. height and 45° dump angle*		3755 mm	3755 mm	3630 mm	3630 mm
Reach at max. height and 45° dump angle*		1355 mm	1355 mm	1455 mm	1455 mm
Reach at 2130 mm clearance and 45° dump angle		2440 mm	2440 mm	2480 mm	2480 mm
Reach with arm horizontal and bucket level		3185 mm	3185 mm	3340 mm	3340 mm
Operating height (fully raised)		6280 mm	6280 mm	6280 mm	6280 mm
Overall length		9305 mm	9305 mm	9460 mm	9460 mm
Loader clearance circle (bucket at carry, outside corner of bucket)		14465 mm	14465 mm	14640 mm	14640 mm
Digging depth:	0°	80 mm	80 mm	100 mm	100 mm
	10°	260 mm	260 mm	290 mm	290 mm
Static tipping load:	straight	14580 kg	14355 kg	14295 kg	14435 kg
	40° full turn	12500 kg	12280 kg	12215 kg	12355 kg
Breakout force		209 kN	209 kN	185 kN	185 kN
Operating weight		23545 kg	23765 kg	23820 kg	23705 kg

*At the end of tooth or bolt on cutting edge (B.O.C.).
 All dimensions, weights, and performance values based on ISO 7131 and 7546 standards.
 Static tipping load and operating weight shown include lubricant, coolant, full fuel tank, ROPS cab, Air conditioner and operator. Machine stability and operating weight affected by counterweight, tire size, and other attachments. Apply the following weight changes to operating weight and static tipping load.



BUCKET SELECTION GUIDE

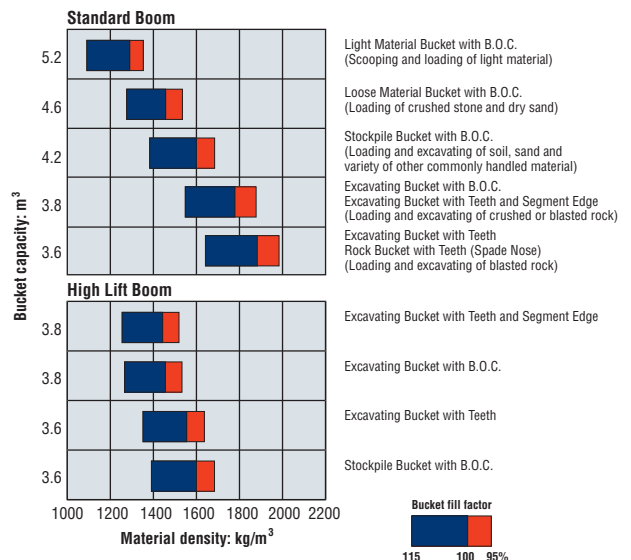



BUCKETS & ATTACHMENTS

■ **Buckets**

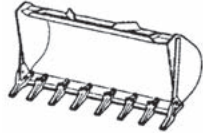
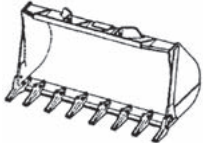
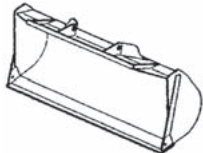
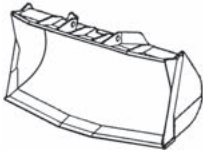
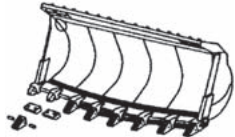
Type	Feature	Image
Stockpile Bucket	This bucket is used for loading stockpile products, such as crushed rock and construction materials.	
Excavating Bucket	This bucket is used for excavating and loading blasted rock on rock crushing job sites, or for excavating natural ground. It has a flat-blade, straight cutting edge, and provides superior rigidity and wear resistance.	
Light Material Bucket	This bucket is used for loading materials with comparatively light specific gravity (below 1.2 t/m ³), such as snow, fertilizer, and livestock feed. It is based on the general purpose bucket, with a lengthened cutting edge and width to give increased capacity. There is also a large capacity coal bucket for loading loose coal with a specific gravity of below 0.89 t/m ³ .	
Spade-nose Rock Bucket (V-edge type)	This bucket is used for excavating and loading blasted rock on rock crushing job sites. It has a pointed cutting edge, and provides superior rigidity and wear resistance.	
Heavy-duty Bucket	This bucket is used for digging and loading blasted rock on rubble mounds and rock crushing job sites. It has 1-class-larger teeth, and a large, thicker wear plate, large corner edge/side guard, and strengthened spill guard. NOTE: When installing this bucket on machines other than the WA700 or WA800, to maintain the stability of the machine, please install an additional counterweight and an orifice (or retainer) for reducing the dumping shock of the bucket.	

■ **Grapples & Forks**

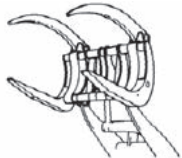
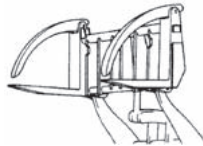
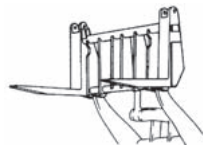
Type	Feature	Image
Log Grapple	This is a special log attachment for use with logs ranging from small-diameter short logs to large-diameter long logs. Its shape enables it to grip the log well with little rolling shock, and it is designed so that the center of gravity of the log is close to the machine body. This enables the machine to maintain its stability when loading and hauling.	
Log-lumber Grapple	The log-lumber grapple is an all-round tool for log and lumber handling capable of dealing with lumber, long logs of large diameter or short logs of small diameter as well as lumber. However, forks of log-lumber grapple are fixed for strength so it is not suitable for use in forklift operations.	
Log-lumber Fork	Log-lumber fork has the same features as log-lumber grapple. This attachment has no top clamps.	



WEIGHT / DIMENSIONS

Tires or attachments	Operating weight	Tipping load straight	Tipping load full turn	Width over tires	Ground clearance	Change in vertical dimensions
	kg	kg	kg	mm	mm	mm
26.5-25-20PR(L-3)	0	0	0	3010	525	0
26.5-25-16PR(L-3)	-70	-50	-45	3010	525	0
26.5-25-20PR(L-4)	355	270	235	3010	525	0
26.5-R25(L-3)	115	90	75	3010	525	0
23.5-25-20PR(L-3)	-460	-350	-300	2920	460	-65
23.5-25-20PR(L-2)	-775	-585	-505	2920	460	-65
Remove ROPS cab with air conditioner	-730	-670	-585			
Install additional counterweight *	400	1030	860			

* Available for the standard boom only.



STANDARD EQUIPMENT

ENGINE/POWER TRAIN:

- Additional fuel filter with water separator
- Engine, Komatsu SAA6D125E-3 diesel
- Service brakes, wet disc type
- Swing-out aftercooler and oil cooler
- Transmission, 4 forward and 4 reverse

ELECTRICAL SYSTEM:

- Alternator, 50 A
- Back-up alarm
- Back-up lamp
- Batteries, 2 x 12 V/136 Ah
- Directional signal
- Engine shut-off system, electric
- Starting motor, 24 V/7.5 kW

HYDRAULIC SYSTEM:

- 2-spool valve for boom and bucket controls
- Lift cylinders and bucket cylinder

CAB:

- Air conditioner
- Auto shift transmission with mode select system
- Equipment Management Monitoring System
- Floor mat
- Main monitor panel with speedometer
- Proportional Pressure Control (PPC) finger top control, two levers
- Rearview mirror
- Rear window washer and wiper
- ROPS/FOPS (ISO 3471/ISO 3449) cab
- Seat, suspension type with reclining
- Seat belt
- Steering wheel, tiltable, telescopic
- Sun visor

WORK EQUIPMENT:

- Boom kick-out
- Bucket positioner
- Counterweight
- Loader linkage with standard lift boom

OTHER EQUIPMENT:

- Front fender
- Radiator mask, lattice type
- Tires (26.5-25-20PR, L-3 tubeless) and rims
- Vandalism protection kit



OPTIONAL EQUIPMENT

ENGINE/POWER TRAIN:

- Brake cooling system
- Engine pre-cleaner with extension
- Limited slip differential (F&R)

ELECTRICAL SYSTEM:

- Batteries, 2 x 12 V/140 Ah
- Battery disconnect switch
- Starting motor, 11 kW

HYDRAULIC SYSTEM:

- 3-spool valve
- Hydraulic-driven fan with reverse rotation

CAB:

- AM/FM radio
- Heater and defroster
- Secondary steering (ISO 5010)

WORK EQUIPMENT:

- Additional counterweight
- Bucket side guard
- Bucket teeth (bolt on type)
- Bucket teeth (tip type)
- Counterweight for log
- Cutting edge (bolt on type)
- Log grapple
- Segmented edges

OTHER EQUIPMENT:

- KOMTRAX
- Ordinary spare parts
- Power train guard
- Tool kit

KOMATSU TOTAL SUPPORT



Komatsu Total Support

To keep your machine available and minimize operation cost when you need it, Komatsu Distributor is ready to provide variety of support before and after procuring the machine.

Fleet recommendation

Komatsu Distributor can study customer job site and provide the most optimum fleet recommendation with detailed information to meet all of your application needs when you are considering to buy new machines or to replace the existing ones from Komatsu.



Product support

Komatsu Distributor secure the certain quality of machine will be delivered.

Parts availability

Komatsu Distributor is available for emergency inquiry by the customers for genuine, quality guaranteed Komatsu parts.

Technical support

Komatsu product support service (Technical support) are designed to help customer. Komatsu Distributor offers a variety of effective services how much Komatsu is dedicated to the maintenance and support of Komatsu machine.

- Preventive Maintenance (PM) clinic
- Oil & Wear analysis program

Repair & maintenance service

Komatsu Distributor offers quality repair service, periodical maintenance, and maintenance service to the customer, utilizing and promoting Komatsu developed programs.

Komatsu Reman (Remanufactured) components

Komatsu Reman products are the result of the implementation of the Komatsu global Reman policy which establishes and agrees to reduce the owning, operating and total Life Cycle Costs (LCC) to Komatsu's customer through prompt delivery, high quality and competitively priced in own remanufactured products (QDC).



