

# KOMATSU®

## WA500-6R

### HORSEPOWER

Gross: 266 kW 357 HP @ 1900 rpm

Net: 263 kW 353 HP @ 1900 rpm

### BUCKET CAPACITY

4.3-5.6 m<sup>3</sup> 5.6-7.3 yd<sup>3</sup>

**WA**  
**500**

W  
H  
E  
E  
L  
L  
O  
A  
D  
E  
R



Photo may include optional equipment.

# WALK-AROUND

## *High Productivity & Low Fuel Consumption*

- High performance Komatsu SAA6D140E-5 engine
- Low fuel consumption
- Dual-mode engine power select system
- Automatic transmission with shift timing select system
- Lock-up Torque Converter (Optional)
- Variable displacement piston pump & CLSS
- Increased bucket capacity
- Long wheelbase

See pages 4 and 5.

## *Excellent Operator Environment*

- Automatic transmission with ECMV
- Low-noise designed cab
- Electronic controlled transmission lever
- Variable transmission cut-off system
- Engine RPM set system with auto decel
- “EPC” (Electronic Pilot Control) levers
- Pillar-less large ROPS/FOPS integrated cab
- Easy entry/exit, rear-hinged door
- Telescopic / tilt steering column

See pages 8 and 9.



## *Harmony with Environment*

- EPA Tier 2 and EU Stage 2 emissions equivalent
- Low exterior noise
- Low fuel consumption

## Increased Reliability

- Reliable Komatsu designed and manufactured components
- Sturdy main frame
- Maintenance-free, fully hydraulic, wet multiple-disc service and parking brakes
- Hydraulic hoses use flat face O-ring seals

See page 6.

- Cation electrodeposition process is used to apply primer paint
- Powder coating process is used to apply main structure paint
- Sealed DT connectors for electrical connections

### HORSEPOWER

Gross: 266 kW 357 HP @ 1900 rpm

Net: 263 kW 353 HP @ 1900 rpm

### BUCKET CAPACITY

4.3–5.6 m<sup>3</sup> 5.6–7.3 yd<sup>3</sup>



Photo may include optional equipment.

## Easy Maintenance

- “EMMS” (Equipment Management Monitoring System)

See page 7.

- Ease of radiator cleaning
- Modular radiator core system

# HIGH PRODUCTIVITY AND LOW FUEL CONSUMPTION

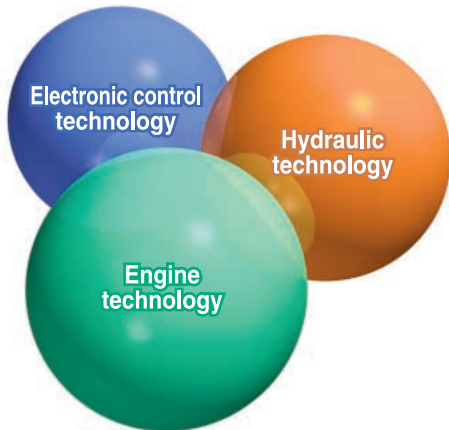

## High Performance Komatsu SAA6D140E-5 Engine

Electronic Heavy Duty Common Rail fuel injection system provides optimum combustion of fuel. This system also provides fast throttle response to match the machine's powerful tractive effort and fast hydraulic response.

**Net: 263 kW 353 HP**

This engine is EPA Tier 2 and EU Stage 2 emissions equivalent.

## Low Fuel Consumption

The fuel consumption is reduced greatly because of the low-noise, high-torque engine and the large-capacity torque converter with maximum efficiency in the low-speed range.

## Dual-mode Engine Power Select System

This wheel loader offers two selectable operating modes—E and P. The operator can adjust the machine's performance with the selection switch.

- **E Mode:** This mode provides maximum fuel efficiency for general loading.
- **P Mode:** This mode provides maximum power output for hard digging operation or hill climb.



Dual mode engine power selection switch



Eco indicator

The eco indicator will help an operator to promote energy saving.

## Automatic Transmission with Mode Select System

This operator controlled system allows the operator to select manual shifting or two levels of automatic shifting (low, and high).

Auto L mode is for fuel saving operation with the gear shift timing set at lower speeds than Auto H mode. Therefore Auto L mode keeps the engine in a relatively low rpm range for

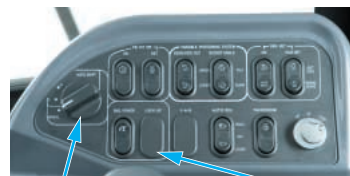

fuel conservation while yielding adequate tractive force by depressing the accelerator pedal.

Shift mode selection switch

Lock up clutch switch (optional)

## Lock-up Torque Converter (Optional)

The Komatsu designed lock-up torque converter provides increased production efficiency, reduced cycle times and optimum fuel savings in load & carry or hill-climb operations. This optional feature allows the operator to activate the system on/off with a switch located on the right-side control panel.

## Variable Displacement Piston Pump & CLSS

New design variable displacement piston pump combined with the Closed-center Load Sensing System delivers hydraulic flow just as the job requires preventing wasted hydraulic pressure. Minimized waste loss contributes to better fuel economy.

- **New Variable Displacement Piston Pump:** The pump delivers only necessary amounts minimizing waste loss.

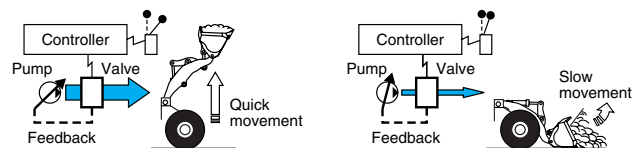

- **Fixed Displacement Piston Pump:** The pump delivers the maximum amount at any time and the unused flow is disposed.

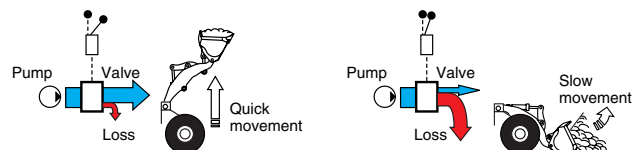



**Increased Bucket Capacity Matches with One Class Higher Dump Truck**



The WA500 enables loading onto 32t (40 Short ton) with the standard spec whereas WA500-6 necessitates the high lift boom with the 4.5m<sup>3</sup> bucket for it. Operator can get good visibility because of high his eye point.

**Dumping Clearance: 3295 mm 10'10"**  
**Dumping Reach: 1500 mm 4'11"**  
 (5.6 m<sup>3</sup> 7.3 yd<sup>3</sup> bucket with B.O.C.)

**Long Wheelbase/Articulation Angle of 40°**

The widest tread in class and the long wheelbase provide improved machine stability in both longitudinal and lateral directions. Since the articulation angle is 40°, the operator can work efficiently even in the tightest job sites.

Tread	<b>2400 mm</b>	7'10"
Wheelbase	<b>3780 mm</b>	12'5"
Minimum turning radius (center of outside tire)	<b>6430 mm</b>	21'1"

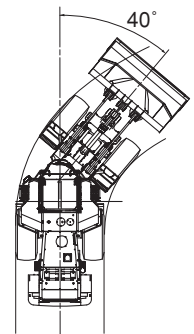

## INCREASED RELIABILITY

### Komatsu Components

Komatsu manufactures the engine, torque converter, transmission, hydraulic units, electric parts, on this wheel loader. Komatsu loaders are manufactured with an integrated production system under a strict quality control system.

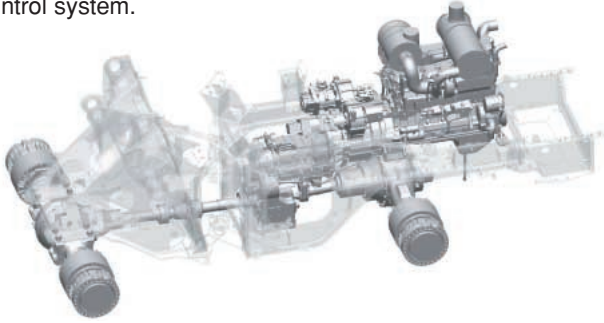

### Wet Multiple-disc Brakes and Fully Hydraulic

**Braking System** mean lower maintenance costs and higher reliability. Wet disc brakes are fully sealed. Contaminants are kept out, reducing wear and maintenance. Brakes require no adjustments for wear, meaning even lower maintenance. The new parking brake is also an adjustment-free, wet multiple-disc for high reliability and long life.

Added reliability is designed into the braking system by the use of two independent hydraulic circuits. Provides hydraulic backup should one of the circuits fail.

Fully hydraulic brakes mean no air system to bleed, or the condensation of water in the system that can lead to contamination, corrosion, and freezing.

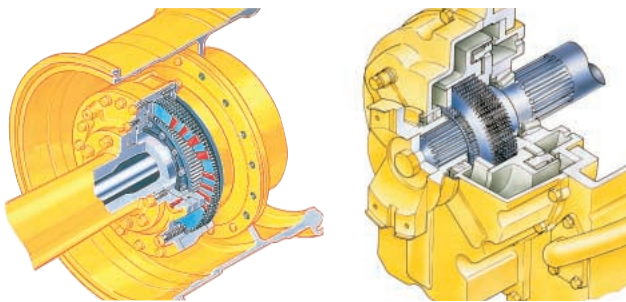

### High-rigidity Frames and Loader Linkage

The front and rear frames and the loader linkage have more torsional rigidity to secure resistance against increased stress due to the use of a larger bucket.

Frame and loader linkage are designed to accommodate actual working loads, and simulated computer testing proves its strength.

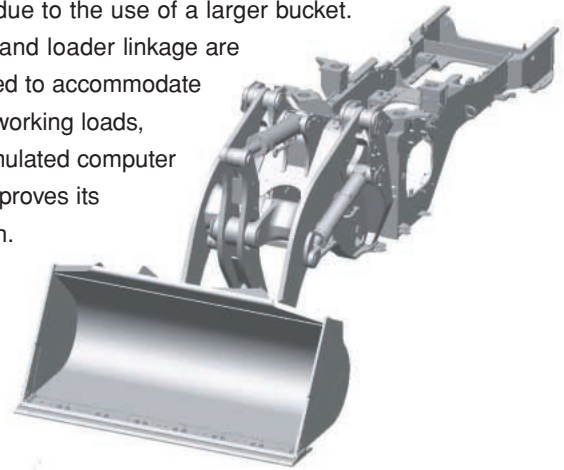

### Flat Face-to-face O-ring Seals

Flat face-to-face O-ring seals are used to securely seal hydraulic hose connections and to prevent oil leakage. In addition, buffer rings are installed to the head side of the all-hydraulic cylinders to lower the load on the rod seals and maximize the reliability.

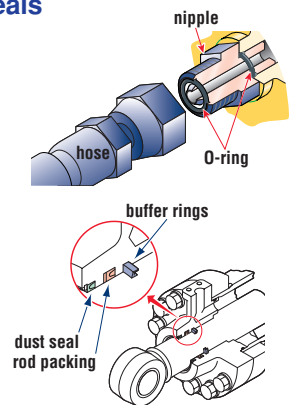

### Cation Electrodeposition Primer Paint/ Powder Coating Final Paint

Cation electrodeposition paint is applied as a primer paint and powder coating is applied as topcoat to the exterior sheet metal parts. This process results in a beautiful rust-free machine, even in the most severe environments. Some external parts are made of plastic providing long life and high impact resistance.

### Sealed DT Connectors

Main harnesses and controller connectors are equipped with sealed DT connectors providing high reliability, water resistance and dust resistance.



# EASY MAINTENANCE



Photo may include optional equipment.

## EMMS (Equipment Management Monitoring System)

Monitor is mounted in front of the operator for easy viewing, allowing the operator to easily check gauges and warning lights. A specially designed two-spoke steering wheel allows the operator to easily see the instrument panel.



## Maintenance Control and Troubleshooting Functions

- **Action code display function:** If abnormality occurs, the monitor displays action details on the character display at the bottom center of the monitor.
- **Monitor function:** Controller monitors engine oil level, pressure, coolant temperature, air cleaner clogging, etc. If controller finds abnormalities, the error is displayed on LCD.
- **Replacement time notice function:** Monitor informs replacement time of oil and filters on LCD when replacement intervals are reached.
- **Trouble data memory function:** Monitor stores abnormalities for effective troubleshooting.

## Gull-wing Type Engine Side Doors Open Wide

The operator can open and close each gull-wing type engine side door easily with the assistance of a gas spring to perform daily service checks from the ground.

## Modular Radiator Core System

The modular radiator core is easy to replace without removing the entire radiator assembly.

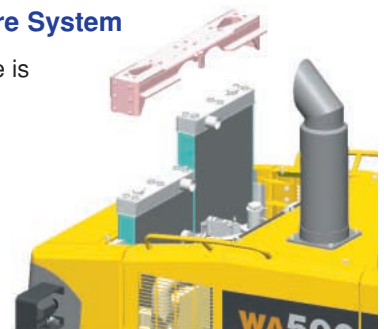

## Ease of Radiator Cleaning



If the machine is operating in adverse conditions, the operator can reverse the hydraulic cooling fan from inside the cab by turning a switch on the control panel.

# OPERATOR ENVIRONMENT

## Easy Operation

### Automatic Transmission with ECMV

Automatic transmission with ECMV automatically selects the proper gear speed based on travel speed, engine speed, and other travel conditions. The ECMV (Electronically Controlled Modulation Valve) system engages the clutch smoothly to prevent lags and shocks when shifting. This system provides efficient machine operation and a comfortable ride.

- **Kick-down**

**switch:** Consider this valuable feature for added productivity. With the touch of a finger, the kick-down switch

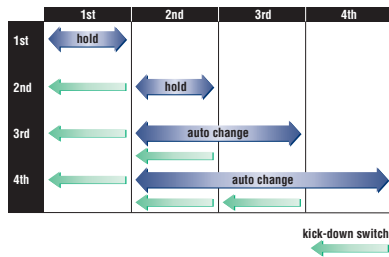

automatically downshifts from second to first when beginning the digging cycle. It automatically upshifts from first to second when the direction control lever is placed in reverse. This results in increased rim pull for better bucket penetration and reduced cycle times for higher productivity.

- **Hold switch:** Auto shift is selected and if the operator turns on this switch when the lever is at the 3rd or 4th gear speed position, the transmission is fixed to that gear speed.

### Electronically Controlled Transmission Lever



Easy shifting and directional changes with Komatsu two-lever electronic shifting. Change direction or shift gears with a touch of the fingers without removing the shifting hand from the steering

wheel. Solid state electronics and conveniently located direction and gear shift controls make this possible. Automatic shifts in ranges two through four keep production high and manual shifting at a minimum.

### Variable Transmission Cut-off System

The operator can continuously adjust the transmission cut-off pressure desired for the left brake pedal using switch located on the right-side control panel. The operator can improve the working performance by setting the cut-off pressure properly depending on working condition.

- High cut-off pressure for digging operations.
- Low cut-off pressure for truck-loading operations.



- 1: Cut-off ON/OFF switch
- 2: Cut-off adjustment switch
- 3: Boom positioner switch
- 4: Bucket digging angle control switch
- 5: RPM set ON/OFF switch
- 6: RPM set adjustment switch
- 7: Semi-auto digging system
- 8: Fan reverse switch
- 9: Boom control
- 10: Bucket control

### Engine RPM Set System with Auto Decel

Engine Low idle RPM can be easily preset using a push button switch. The system provides auto decel for better fuel consumption.



## Comfortable Operation

### EPC (Electronic Pilot Control) Levers

The EPC work equipment control lever is a finger controlled lever having light operating effort and short stroke. The operator can operate easy and comfortable with full adjustable large size arm rest. Combined with CLSS, this system allows following new functions for easy and efficient operation.



- Remote Boom Positioner with shockless stop function:** The highest and lowest position of the bucket can be set from cab to match of any truck body. Once the positioner is set, the bucket is smoothly stopped at desired position with no shock.
- Remote bucket digging angle control:** The digging bucket angle can be easily set from cab to match of ground condition.
- Semi-auto digging system (optional):** Bucket tilt operation can be automatically done when digging.

### Telescopic/Tilt Steering Column

The operator can tilt and telescope the steering column to provide a comfortable working position.



### Low-noise Design

Noise at operator's ear noise level : 76 dB(A)  
Dynamic noise level (outside): 109 dB(A)

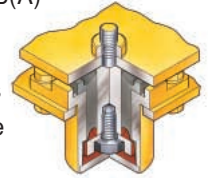

The large cab is mounted with Komatsu's unique ROPS/FOPS viscous mounts. The low-noise engine, hydraulically driven fan, and hydraulic pumps are mounted with rubber cushions, and the cab sealing is improved to provide a quiet, low-vibration, dustproof with pressurizing, and comfortable operating environment. Also, exterior noise is lowest in this class.



### Pillar-less Large Cab

A wide pillar-less flat glass provides excellent front visibility. The wiper arm covers a large area to provide great visibility even on rainy days.

The cab area is the largest in its class providing maximum space for the operator. Increased seat slide adjustment to backward by introducing front mounted air conditioner unit.

### Rear-hinged Full Open Cab Door

The cab door hinges are installed to the rear side of the cab providing a large opening angle for the operator to enter and exit. The steps are designed like a staircase, so that the operator can get on and off the cab easily.



# SPECIFICATIONS



## ENGINE

Model .....Komatsu SAA6D140E-5  
 Type .....Water-cooled, 4-cycle  
 Aspiration .....Turbocharged, aftercooled  
 Number of cylinders .....6  
 Bore x stroke .....**140 mm x 165 mm** 5.51" x 6.50"  
 Piston displacement .....**15.24 ltr** 930 in<sup>3</sup>  
 Governor .....all-speed, electronic  
 Horsepower  
 SAE J1995 .....Gross **266 kW** 357 HP  
 ISO 9249/SAE J1349\* .....Net **263 kW** 353 HP  
 Rated rpm .....1900 rpm  
 Fan drive method for radiator cooling .....Hydraulic  
 Fuel system .....Direct injection  
 Lubrication system:  
 Method .....Gear pump, force-lubrication  
 Filter .....Full-flow type  
 Air cleaner .....Dry type with double elements and  
 dust evacuator, plus dust indicator

\*Net horsepower at the maximum speed of radiator cooling fan is 248 kW 332 HP.

EPA Tier 2 and EU Stage 2 emissions equivalent.



## TRANSMISSION

Torque converter:  
 Type .....3-element, single-stage, single-phase  
 Transmission:  
 Type .....Full-powershift, planetary type  
 Travel speed: **km/h** mph  
 Measured with 29.5-25 tires

	1st		2nd		3rd		4th	
Forward	7.7	4.8	12.5	7.8	22.3	13.9	37.0	23.0
Reverse	8.6	5.3	13.0	8.1	24.8	15.4	39.0	24.2



## AXLES AND FINAL DRIVES

Drive system .....Four-wheel drive  
 Front .....Fixed, full-floating  
 Rear .....Center-pin support, full-floating,  
 24° total oscillation  
 Reduction gear .....Spiral bevel gear  
 Differential gear .....Conventional type  
 Final reduction gear .....Planetary gear, single reduction



## BRAKES

Service brakes .....Hydraulically actuated,  
 wet multiple-disc brakes actuate on four wheels  
 Parking brake .....Wet multiple-disc brake  
 Emergency brake .....Parking brake is commonly used



## STEERING SYSTEM

Type .....Articulated type, full-hydraulic power steering  
 Steering angle .....40° each direction  
 Minimum turning radius at  
 the center of outside tire .....**6430 mm** 21'1"



## HYDRAULIC SYSTEM

Steering system:  
 Hydraulic pump .....Piston pump  
 Capacity .....**120 ltr/min** 31.7 U.S. gal/min at max. control flow  
 Relief valve setting .....**24.5 MPa** 250 kgf/cm<sup>2</sup> 3,550 psi  
 Hydraulic cylinders:  
 Type .....Double-acting, piston type  
 Number of cylinders .....2  
 Bore x stroke .....**100 mm x 486 mm** 3.9" x 19.1"

Loader control:  
 Hydraulic pump .....Piston pump  
 Capacity .....**320 ltr/min** 84.5 U.S. gal/min at rated rpm  
 Relief valve setting .....**34.3 MPa** 350 kgf/cm<sup>2</sup> 4,980 psi  
 Hydraulic cylinders:  
 Type .....Double-acting, piston type  
 Number of cylinders—bore x stroke:  
 Lift cylinder .....2- **160 mm x 898 mm** 6.3" x 35.4"  
 Bucket cylinder .....1- **185 mm x 675 mm** 7.3" x 26.6"

Control valve .....2-spool type  
 Control positions:  
 Boom .....Raise, hold, lower, and float  
 Bucket .....Tilt-back, hold, and dump  
 Hydraulic cycle time (rated load in bucket)  
 Raise .....7.2 sec  
 Dump .....1.7 sec  
 Lower (Empty) .....4.2 sec



## SERVICE REFILL CAPACITIES

Cooling system .....**120 ltr** 31.7 U.S. gal  
 Fuel tank .....**473 ltr** 124.9 U.S. gal  
 Engine .....**45 ltr** 11.9 U.S. gal  
 Hydraulic system .....**337 ltr** 89.0 U.S. gal  
 Axle front .....**87 ltr** 22.9 U.S. gal  
 rear .....**81 ltr** 21.4 U.S. gal  
 Torque converter and transmission .....**76 ltr** 20.0 U.S. gal



## BUCKET SELECTION GUIDE

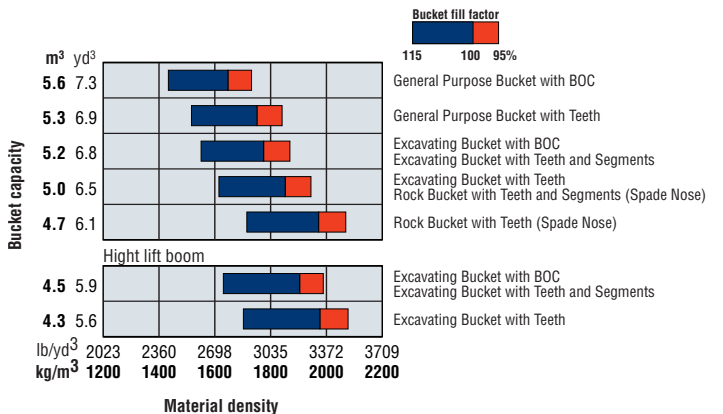



## DIMENSIONS

Measured with 29.5-25-22PR (L3) tires

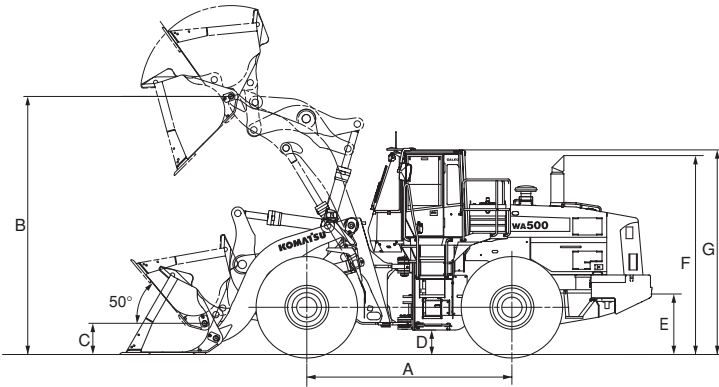

Tread	2400 mm	7'10"
Width over tires	3190 mm	10'6"
A Wheelbase	3780 mm	12'5"
B Hinge pin height, max. height	4755 mm	15'7"
C Hinge pin height, carry position	575 mm	1'11"
D Ground clearance	450 mm	1'6"
E Hitch height	1115 mm	3'8"
F Overall height, top of the stack	3665 mm	12'0"
G Overall height, ROPS cab	3785 mm	12'5"

	Standard boom						High lift boom			
	General Purpose Buckets		Excavating Buckets			Rock Buckets		Excavating Buckets		
	Straight edge Bolt-on Cutting edges	Straight edge Teeth	Straight edge Bolt-on Cutting edges	Straight edge Teeth and Segments	Straight edge Teeth	Spade nose Teeth and Segments	Spade nose Teeth	Straight edge Bolt-on Cutting edges	Straight edge Teeth and Segments	Straight edge Teeth
Bucket capacity: heaped	5.6 m <sup>3</sup> 7.3 yd <sup>3</sup>	5.3 m <sup>3</sup> 6.9 yd <sup>3</sup>	5.2 m <sup>3</sup> 6.8 yd <sup>3</sup>	5.2 m <sup>3</sup> 6.8 yd <sup>3</sup>	5.0 m <sup>3</sup> 6.5 yd <sup>3</sup>	5.0 m <sup>3</sup> 6.5 yd <sup>3</sup>	4.7 m <sup>3</sup> 6.1 yd <sup>3</sup>	4.5 m <sup>3</sup> 5.9 yd <sup>3</sup>	4.5 m <sup>3</sup> 5.9 yd <sup>3</sup>	4.3 m <sup>3</sup> 5.6 yd <sup>3</sup>
struck	4.8 m <sup>3</sup> 6.3 yd <sup>3</sup>	4.5 m <sup>3</sup> 5.9 yd <sup>3</sup>	4.2 m <sup>3</sup> 5.5 yd <sup>3</sup>	4.2 m <sup>3</sup> 5.5 yd <sup>3</sup>	4.0 m <sup>3</sup> 5.2 yd <sup>3</sup>	4.2 m <sup>3</sup> 5.5 yd <sup>3</sup>	4.0 m <sup>3</sup> 5.2 yd <sup>3</sup>	3.7 m <sup>3</sup> 4.8 yd <sup>3</sup>	3.7 m <sup>3</sup> 4.8 yd <sup>3</sup>	3.5 m <sup>3</sup> 4.6 yd <sup>3</sup>
Bucket width	3400 mm 11'2"	3460 mm 11'4"	3400 mm 11'2"	3460 mm 11'4"	3460 mm 11'4"	3460 mm 11'4"	3460 mm 11'4"	3400 mm 11'2"	3460 mm 11'4"	3460 mm 11'4"
Bucket weight	3110 kg 6,855 lb	2955 kg 6,515 lb	3055 kg 6,735 lb	3145 kg 6,935 lb	2900 kg 6,395 lb	3745 kg 8,255 lb	3490 kg 7,695 lb	2885 kg 6,360 lb	2975 kg 6,560 lb	2730 kg 6,020 lb
Dumping clearance, max. height and 45° dump angle*	3295 mm 10'10"	3165 mm 10'5"	3395 mm 11'2"	3265 mm 10'9"	3265 mm 10'9"	3030 mm 9'11"	3030 mm 9'11"	3890 mm 12'9"	3760 mm 12'4"	3760 mm 12'4"
Reach at max. height and 45° dump angle*	1500 mm 4'11"	1600 mm 5'3"	1400 mm 4'7"	1495 mm 4'11"	1495 mm 4'11"	1725 mm 5'8"	1725 mm 5'8"	1435 mm 4'8"	1530 mm 5'0"	1530 mm 5'0"
Reach at 2130 mm (7') clearance and 45° dump angle	2300 mm 7'7"	2340 mm 7'8"	2215 mm 7'3"	2285 mm 7'6"	2285 mm 7'6"	2400 mm 7'10"	2400 mm 7'10"	2585 mm 8'6"	2645 mm 8'8"	2645 mm 8'8"
Reach with arm horizontal and bucket level	3265 mm 10'9"	3425 mm 11'3"	3120 mm 10'3"	3280 mm 10'9"	3280 mm 10'9"	3610 mm 11'10"	3610 mm 11'10"	3385 mm 11'1"	3545 mm 11'8"	3545 mm 11'8"
Operating height (fully raised)	6430 mm 21'1"	6430 mm 21'1"	6415 mm 21'1"	6415 mm 21'1"	6415 mm 21'1"	6630 mm 21'9"	6630 mm 21'9"	6715 mm 22'0"	6715 mm 22'0"	6715 mm 22'0"
Overall length	9815 mm 32'2"	9975 mm 32'9"	9670 mm 31'9"	9790 mm 32'1"	9790 mm 32'1"	10155 mm 33'4"	10155 mm 33'4"	10030 mm 32'11"	10190 mm 33'5"	10190 mm 33'5"
Loader clearance circle (bucket at carry, outside corner of bucket)	15300 mm 50'2"	15460 mm 50'9"	15220 mm 49'11"	15380 mm 50'6"	15380 mm 50'6"	15290 mm 50'2"	15290 mm 50'2"	15610 mm 51'3"	15780 mm 51'9"	15780 mm 51'9"
Digging depth: 0°	135 mm 5"	155 mm 6"	135 mm 5"	155 mm 6"	155 mm 6"	165 mm 6"	165 mm 6"	210 mm 8"	235 mm 9"	235 mm 9"
10°	435 mm 1'5"	485 mm 1'7"	410 mm 1'4"	460 mm 1'6"	460 mm 1'6"	525 mm 1'9"	525 mm 1'9"	470 mm 1'7"	520 mm 1'8"	520 mm 1'8"
Static tipping load: straight	24300 kg 53,570 lb	24500 kg 54,010 lb	24450 kg 53,900 lb	24340 kg 53,660 lb	24655 kg 54,355 lb	23700 kg 52,245 lb	24020 kg 52,955 lb	22405 kg 49,395 lb	22290 kg 49,140 lb	22595 kg 49,810 lb
40° full turn	21000 kg 46,295 lb	21170 kg 46,670 lb	21130 kg 46,580 lb	21035 kg 46,370 lb	21305 kg 46,965 lb	20480 kg 45,150 lb	20755 kg 45,755 lb	19360 kg 42,680 lb	19260 kg 42,460 lb	19525 kg 43,045 lb
Breakout force	245 kN 25000 kgf 55,115 lb	262 kN 26750 kgf 58,975 lb	268 kN 27300 kgf 60,185 lb	274 kN 27950 kgf 61,620 lb	288 kN 29400 kgf 64,815 lb	233 kN 23800 kgf 52,470 lb	243 kN 24750 kgf 54,565 lb	286 kN 29140 kgf 64,245 lb	294 kN 30000 kgf 66,140 lb	310 kN 31620 kgf 69,710 lb
Operating weight	33360 kg 73,545 lb	33205 kg 73,200 lb	33305 kg 73,425 lb	33395 kg 73,620 lb	33150 kg 73,080 lb	33995 kg 75,945 lb	33740 kg 74,380 lb	34380 kg 75,795 lb	34470 kg 75,990 lb	34225 kg 75,450 lb

\* At the end of tooth or B.O.C.

All dimensions, weights, and performance values based on SAE J732c and J742b standards.

Static tipping load and operating weight shown include lubricant, coolant, full fuel tank, ROPS cab, and operator. Machine stability and operating weight affected by counterweight, tire size, and other attachments.

Apply the following weight changes to operating weight and static tipping load.



## WEIGHT CHANGES

Tires or attachments	Operating weight		Tipping load straight Standard Boom		Tipping load full turn Standard Boom		Width over tires		Ground clearance		Change in vertical dimensions	
	kg	lb	kg	lb	kg	lb	mm	ft in	mm	ft in	mm	ft in
29.5-25-22PR(L-3)	0	0	0	0	0	0	3190	10'6"	450	1'6"	0	0
Install additional counterweight	+900	+1,985	+1865	+4,110	+1645	+3,625						
Air conditioner	+65	+145	+33	+75	+30	+65						
Emergency steering	+70	+155	+65	+145	+55	+120						
Lock-up clutch torque converter	+45	+100	+60	+130	+50	+110						
ECCS (Electronically Controlled Suspension System)	+120	+265	+13	+30	+11	+24						



## STANDARD EQUIPMENT

- 2-spool valve for boom and bucket controls
- Air conditioner
- Alternator, 75 A/24 V
- Auto shift transmission with mode select system
- Back-up alarm
- Back-up lamp
- Batteries, 170 Ah/12 V x 2
- Counterweight
- Directional signal
- Engine, Komatsu SAA6D140E-5 diesel
- Engine shut-off system, electric
- EPC fingertip control levers with automatic leveler and positioner
- Floor mat
- Front fender
- Hard water area arrangement (corrosion resister)
- Hydraulic-driven fan with reverse rotation
- Lift cylinders and bucket cylinder
- Main monitor panel with EMMS (Equipment Management Monitoring System)
- Radiator mask, lattice type
- Rear under view mirror
- Rearview mirror for cab
- Rear window washer and wiper
- ROPS/FOPS cab
- Seat, air-suspension type with reclining
- Seat belt
- Service brakes, wet disc type
- Starting motor, 11.0 kW/24 V
- Steering wheel, tiltable
- Sun visor
- Tires (29.5-25-22PR tubeless) and rims
- Transmission, 4 forward and 4 reverse
- Vandalism protection kit



## OPTIONAL EQUIPMENT

- 12V converter
- Additional counterweight
- Alternator, 90A/24V
- AM/FM radio
- AM/FM stereo radio cassette
- Batteries, 220 Ah/12V x 2
- Battery disconnect switch
- Brake cooling system
- Bucket teeth (bolt-on type)
- Bucket teeth (tip type)
- Cab heater and defroster
- Cutting edge (bolt-on type)
- ECSS (Electronically Controlled Suspension System)
- Emergency steering (SAE)
- Fire extinguisher
- FNR directional change switch
- Fuel quick coupler
- High lift boom
- In-line filter
- Joystick steering
- Load meter, new type
- Lock-up clutch torque converter
- Ordinary spare parts
- Power train guard
- Seat, air suspension with automatic weight adjustment
- Segment edges
- Tool kit
- Limited slip differential (F&R)

www.Komatsu.com

Printed in Japan 201401 IP.SIN

# KOMATSU®

CEN00253-02

Materials and specifications are subject to change without notice  
**KOMATSU** is a trademark of Komatsu Ltd. Japan